

USER MANUAL 1.8

Astraada One Compact HMI Pro



Trademarks

- CANtrol® and CANtrol®-dialog are registered trademarks.
- Microsoft®, Windows® and the Windows® logo are registered trademarks of Microsoft Corp. in the USA and other countries.
- EtherCAT® is a registered trademark and a patented technology, licensed by Beckhoff Automation GmbH, Germany.
- CiA® and CANopen® are registered community trademarks of CAN in Automation e. V.
- ARM® and Cortex® are registered trademarks of ARM Limited.
- PROFINET® is a registered trademark of PROFIBUS Nutzerorganisation e. V.
- Modbus® is a registered trademark of the Modbus-IDA organisation.
- i.MX6 is a registered trademark of Freescale.

The rights of all companies and company names mentioned in this document as well as products and product names belong to the respective companies.

Notes about this handbook

This equipment handbook contains information which is specific to the product and valid at the time of printing.

This equipment handbook is only complete in conjunction with the product-related hardware and software manuals required for the specific application.

You can contact us at:

ASTOR Sp z o.o.

ul. Smoleńsk 29

31-112 Kraków

Poland

T: 12 428 63 00

E-mail: info@astor.com.pl

<https://www.astor.com.pl/>

Astraada One Compact HMI Pro is certified to DIN EN ISO 9001 in the respective current version.

Revision log

Version	Date	Description
0.1	13/08/2019	Initial version
0.9	27/04/2020	Update with new catalogue numbers
1.0	18/06/2020	Formatting revised in the document
1.2	05/03/2021	Dual Core versions added
1.3	16/09/2022	Cyber security added
1.4	17/03/2023	Correction temperature values and others, Supplement RMA process, Consumption, Cyber-Security, Nameplate, Change module configuration S01 + S02 Compact HMI Pro 4/7
1.5	03/04/2023	Correction device configuration
1.6	17/11/2023	Adaption Cyber security
1.7	27/05/2024	Supplement to power supply connector X10 for versions S01 and S02
1.8	06/09/2024	Update current consumption values

Table of contents

1	GENERAL INFORMATION	7
1.1	Notes about this handbook	7
1.2	Symbols and visual depictions	7
1.3	Hazard categories and indications	8
1.4	Qualified personnel	9
1.5	Duty of care	9
1.5.1	General	9
1.6	Intended use	10
1.7	Transport and storage	11
	Transport and storage	11
	Operation	11
	Devices with (rechargeable) batteries	11
1.8	Unpacking	11
2	SAFETY	12
2.1	Safety-related systems	12
2.2	Safety instructions	12
	Working on the device	13
2.3	Cybersecurity	13
3	PRODUCT DESCRIPTION	14
3.1	Overview	15
3.1.1	Compact HMI Pro 4/7	15
3.1.2	Compact HMI Pro 10/15	16
3.2	Scope of delivery and accessories	17
	Scope of delivery	17
	Accessories	17
3.3	Product features	18
3.3.1	Assembly	18
3.3.2	Processor	18
3.3.3	Ethernet	18
3.3.4	USB	18
	CAN interfaces	18
	Serial interfaces	18
	Onboard analogue inputs/outputs	18
	Additional interfaces	18
	Real-time clock	19
	microSD card	19
	Summary of features of Compact HMI Pro 4, Compact HMI Pro 7	19
	Summary of features of Compact HMI Pro 10 and 10 Pro 15	19
4	ASSEMBLY	20
4.1	Preparation for installation	20

4.1.1	Compact HMI Pro 4 dimensions	21
4.1.2	Compact HMI Pro 4 installation cut-out	22
4.1.3	Compact HMI Pro 7 dimensions	23
4.1.4	Compact HMI Pro 7 installation cut-out	24
4.1.5	Compact HMI Pro 10 dimensions	25
4.1.6	Compact HMI Pro 10 installation cut-out	26
4.1.7	Compact HMI Pro 15 dimensions	27
4.1.8	Compact HMI Pro 15 installation cut-out	28
4.2	Installation	29
4.2.1	Compact HMI Pro 4/7 installation	29
4.2.2	Compact HMI Pro 10 installation	31
4.2.3	Compact HMI Pro 15 installation	33
5	CONNECTION	35
5.1	Power supply	35
5.1.1	Connecting the power supply	36
5.1.2	Compact HMI Pro 4/7 power supply	36
5.1.3	Compact HMI Pro 10/15 power supply	37
5.2	Data connections	38
5.2.1	Block diagram	38
5.2.2	Digital inputs and outputs (not all modules)	40
5.2.3	Counting inputs (C)	45
5.2.4	Analogue inputs (not all modules)	47
5.2.5	Ethernet	54
5.2.6	EtherCAT	55
5.2.7	USB	56
5.2.8	CAN bus (not all modules)	57
5.2.9	Serial interfaces (from S04 onwards only)	58
6	OPERATION	60
6.1	Switching on and off	60
6.2	Initial start-up of the network	61
6.2.1	Web interface configuration	61
6.2.2	On-screen configuration	63
6.3	Operation	64
6.3.1	Status indicators	64
6.3.2	Function key (S1)	66
6.3.3	Real time clock with battery back-up	66
6.3.4	microSD Card (not all modules)	67
6.4	Troubleshooting	68
6.4.1	No network connection	68
6.4.2	In error stop mode	68
7	SERVICING / MAINTENANCE	69
7.1	Maintenance	69
7.2	Cleaning	69
7.3	Chemical resistance	70
7.3.1	Resistance of the touch screen	70

7.3.2	Resistance of the front membrane display	70
8	DISASSEMBLY	72
8.1	Disassembling the Compact HMI Pro 4/7	72
8.2	Disassembly of the Compact HMI Pro 10/15	74
9	DISPOSAL	76
10	INFORMATION AND OPTIONS	77
10.1	Type plate	81
10.2	Device variants and identification	82
10.3	Options and extensions	83
11	CERTIFICATES	84
11.1	Standards	84
12	APPENDIX	85
12.1	Notes on copyright and the software licence	85
12.2	List of figures	85

1 General information

This user handbook is intended for use by qualified personnel and contains information on the assembly, installation, start-up and maintenance of the device.

1.1 Notes about this handbook

This user handbook is a component of the product and applies to the following devices:

- ASTRAADA ONE COMPACT HMI PRO 4
- ASTRAADA ONE COMPACT HMI PRO 7
- ASTRAADA ONE COMPACT HMI PRO 7
- ASTRAADA ONE COMPACT HMI PRO 10
- ASTRAADA ONE COMPACT HMI PRO 15

It contains information on the following topics:

- Areas of application
- Safety
- Mechanical design
- Electrical design
- Connections
- Start-up
- Servicing and maintenance
- Decommissioning
- Disposal

- ▶ Keep this user handbook available alongside the product at all times.

1.2 Symbols and visual depictions

The following symbols and visual depictions are used in this user handbook:

Symbol	Meaning
→ ...	List entry
▶ ...	Individual instruction or list of instructions which can be carried out in any order.
1. ...	List of instructions which must be carried out in the order given.
2. ...	
	Additional product information

Structure of the warnings:

WARNING

Optional:	Type and source of the danger
More symbols	Brief description and consequences ▶ Preventive measures

1.3 Hazard categories and indications

The following indications are used for warning messages that must be observed to ensure your personal safety and avoid any damage to property.

The indications have the following meanings:

DANGER

Serious injury or death

Failure to observe the safety measures will result in death or serious injury.

- ▶ Take preventive measures.
-

WARNING

Possible serious injury or death

Failure to observe the safety measures may result in death or serious injury.

- ▶ Take preventive measures.
-

CAUTION

Possible minor injuries

Failure to observe the safety measures may result in minor injuries.

- ▶ Take preventive measures.
-

NOTICE

Possible damage to property

Failure to observe the safety measures may result in damage to property.

- ▶ Take preventive measures.
-

1.4 Qualified personnel

The installation, start-up and maintenance of the machine must be carried out by qualified personnel. For the purposes of this documentation and the safety instructions contained therein, “qualified personnel” means trained staff with the authorization to assemble, install, start up, earth and identify devices, systems and electrical circuits in accordance with the standards set in safety engineering and who are familiar with safety concepts in automation engineering.

1.5 Duty of care

1.5.1 General

The user or processor (OEM) must ensure the following:

- The device must only be used for its intended purpose.
- The device must only be used in a perfect, fully functional condition.
- The user handbook must always be kept legible and fully available.
- Only sufficiently qualified and authorized personnel carry out assembly, installation, start-up and maintenance of the device.
- This authorized personnel must receive regular training in all relevant questions of occupational health and safety and environmental protection and must be familiar with the contents of this user handbook, particularly the sections containing safety instructions.
- Any markings or identification labels and safety and warning signs on the device must not be removed and must be kept legible at all times.
- The national and international regulations regarding the operation of machinery and installations where the device is being used must be observed.
- The user must always be kept abreast of any current relevant information regarding the device and its use or operation.
- The user is responsible for coordinating the use of the safety-related control components with the responsible authority and for adhering to its specifications.

1.6 Intended use

The devices are components of the CANtrol modular automation system based on CAN bus for industrial control applications in the medium to high performance range. It extends the communication options with EtherCAT, Profinet or Modbus for example.

The automation system is designed for use in overvoltage category I (IEC 364-4-443) for the control and regulation of machinery and industrial processes in low-voltage installations in accordance with the following basic conditions:

- Maximum rated supply voltage of 1,000 V AC (50/60 Hz) or 1,500 V DC
- For use in an environment with max. category 2 level of pollution (EN 60950)
- For use in a maximum altitude of 2,000 m a.s.l.
- For indoor use in areas not exposed to direct UV radiation
- Max. ambient temperature inside and outside the control cabinet according to the technical specifications (see “ Information and options”).
- Not for use in residential areas (270011500 only)



The 270011500 device is not designed for use in residential areas and is unable to guarantee adequate EMC immunity & emissions in such environments.

Correct and safe operation of the automation system requires qualified project planning, proper transport, storage, installation and use as well as careful maintenance.

The automation system may only be used within the scope of the information and applications specified in this documentation and associated user handbooks.

The automation system must only be used as follows:

- As intended
 - In technically perfect condition
 - Without unauthorized modifications
 - By qualified users only
- ▶ Observe the rules of the employers' liability insurance association, the German Technical Inspection Association (TÜV), the Association of German Electrical Engineers (VDE) or relevant national regulations.

The device is intended for installation in a suitable installation cut-out in industrial machines and systems in indoor areas.

- ▶ During installation, make sure that the existing seal profiles are undamaged.
- ▶ For operation, refer to the applicable ambient conditions (see “Technical data”).

1.7 Transport and storage

The device is susceptible to impacts, heavy vibrations, moisture and extreme temperatures.

Transport and storage

- ▶ Protect the device from heavy mechanical stresses during transport.
- ▶ Always transport the device in its original packaging.
- ▶ For storage, refer to the applicable ambient conditions.
- ▶ Protect the device from condensation and moisture.

Operation

- ▶ If the device has been stored or transported in cold weather or under conditions of large fluctuations in temperature, do not start to operate it until it has acclimatized to room temperature for the place in which it is used.
- ▶ Wait at least 12 hours after it has reached room temperature before operating the device.

Devices with (rechargeable) batteries

Lithium metal batteries are a hazardous material. According to the manufacturers, they fall under UN 3091 (contained in the device).

Special provision 188 of the ADR can be applied for transport.

1.8 Unpacking

Upon receipt of the device, make sure that it is undamaged and complete.

- ▶ Check the packaging for external damage.
- ▶ If the packaging is seriously damaged or if damage to the contents is evident: do not proceed further with opening the packaging; instead immediately inform the transport company and your supplier.
- ▶ Remove the packaging and keep it safe for subsequent transport.
- ▶ Check the contents for evidence of damage in transport.
- ▶ Check the contents for completeness against the order documentation and keep all delivery documentation for future reference. The delivery documentation contains important information about the device and is part of the product.
- ▶ If you notice any damage in transport or the contents do not match the order: inform the suppliers immediately.

2 Safety

2.1 Safety-related systems

The use of PLC controls in safety-related systems requires specific measures. If a PLC controller is to be used in a safety-related system, the user must be given comprehensive advice by the PLC manufacturer in addition to any available standards or guidelines regarding safety installations.

- ▶ Before starting work on the devices, switch off all power supplies, including those of connected peripherals.
- ▶ Keep all ventilation openings unobstructed.

The failure of certain components in an electronic control system may result in uncontrolled and/or unpredictable operational behaviour.

- ▶ All types of failure must be considered at the system level and the associated preventative measures identified.
- ▶ If necessary, request information from your automation system provider.

2.2 Safety instructions

CAUTION

Possible minor injuries and/or burning of the surface of the skin

Non-compliance with the safety features may result in minor injuries / burning of the surface of the skin

The device may only be operated only when it is in good working order. Exposed sharp edges or broken glass pose an injury risk.

- ▶ If you detect damage to the front glass of the device, stop operating the device and immediately disconnect it from the power supply.

The device may heat up during operation, especially in hot environments, because of the passive cooling mechanism of the electronics inside. The surface temperature may be high enough to cause burning if there is prolonged contact with the human skin.

- ▶ If possible, avoid touching the rear panel of the device during operation.
- ▶ If you plan to work on e.g. the installation or cabling of the device, first shut it down by disconnecting the power supply and let it cool down for a while.
- ▶ It is recommended to wear personal protective equipment, e.g. protective gloves when handling the warmed up device.

Working on the device

Do not start work on the device until all necessary safety precautions have been taken. Take precautions to avoid unforeseeable functional events and movements of the system.

- ▶ Bring the system into a safe state.
- ▶ Switch the system and the device off.
- ▶ Secure the system against being switched on again.
- ▶ Disconnect the device from the system.

Do not open the device housing.

- ▶ If it is necessary to work on internal parts of the device, contact the manufacturer.

2.3 Cybersecurity

- ▶ Never place the control unit on the Internet without additional protection mechanisms, this product is not designed for this purpose
- ▶ Change the default passwords specified on delivery
- ▶ Always use an upstream external firewall to prevent access from the outside to the inside.
- ▶ Use the security mechanisms of VPN server portals (e.g. IXON) to which the controller can actively connect via VPN or comparable mechanisms
- ▶ Always use https instead of http
- ▶ Deactivate unnecessary services such as (FTP/SSH/Webserver)

3 Product description

The Astraada One Compact HMI Pro is a control module without a display for the control and regulation of machinery and industrial processes in low-voltage installations in real time. The following display sizes are available: 4.3", 7", 10.1" and 15.6 for Compact HMI Pro Series. The Astraada One Compact HMI Pro series can be connected via various interfaces and also have their own digital and analogue inputs and outputs.

The development environment CODESYS 3.5 (IEC 61131-3) from CODESYS (former Smart Software Solutions) is used for programming.

The device's connection area for all external connections is located at the rear. These devices are intended for installation on a flat surface in a pre-prepared installation cut-out.

All the connections are of the plug-in type.

3.1 Overview

3.1.1 Compact HMI Pro 4/7

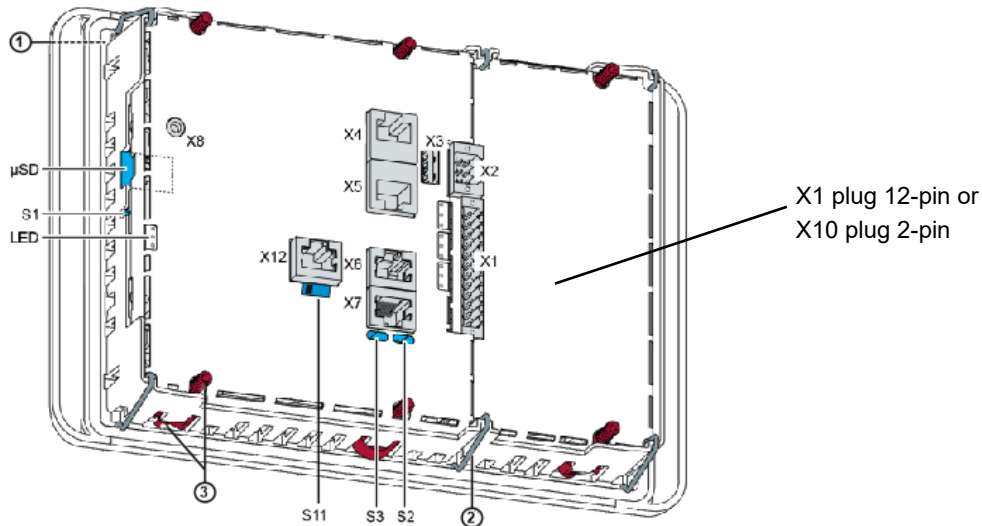

Fig. 1: Overview of Compact HMI Pro 4/7 (rear)

No.	Designation	No.	Designation
1	Display 4.3 or 7 inch	X8	Debug interface (do not use - only for Service Engineers)
2	Fastening clip (2 or 3 pcs)	X10	Power supply (only version S01 and S02)
3	Twist-lock catch (4 or 6 pcs) ¹	X12	CAN-Bus [CAN1] (only version S05)
X1	Power supply, digital inputs/outputs	S1	Function key (Reset and Run/Stop)
X2	Analogue inputs	S2	Terminating resistor CAN [CAN0] (120 Ohm)
X3	USB 2.0	S3	Terminating resistor RS-485 [COM2] (120 Ohm)
X4	Ethernet [ETH0] ²	S11	Terminating resistor CAN [CAN1] (120 Ohm) (only version S05)
X5	EtherCAT [ETH1], also configurable as Ethernet	μSD	MicroSD card slot
X6	RS-232 [COM1] / RS-485 [COM2]	LED	LEDs: PWR, Run/Stop, Error
X7	CAN-Bus [CAN0]		

¹ Only required for protection rating IP65

² Designations in []: CODESYS-designations of the connections

3.1.2 Compact HMI Pro 10/15

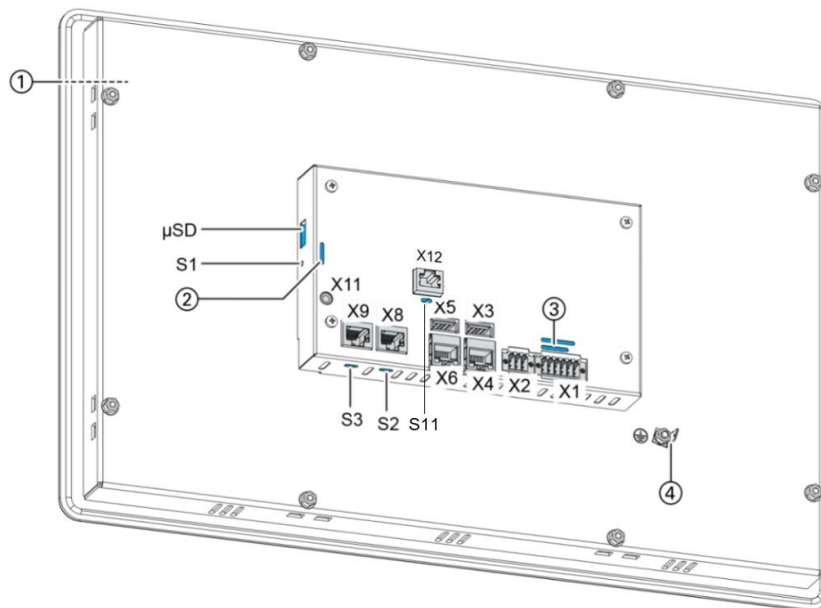

Fig. 3: Overview of Compact HMI Pro 10/15 (rear)

No.	Designation	No.	Designation
1	Display 10.1 or 15.6 inch	X8	CAN-Bus [CAN0]
2	LEDs: PWR, Run/Stop, Error	X9	RS-232 [COM1] / RS-485 [COM2]
3	LEDs: Power supply, digital I/O	X11	Debug interface (do not use - only for Service Engineers)
4	Earth connection	X12	CAN bus [CAN1] (only version S05)
X1	Power supply, digital inputs/outputs	S1	Function key (Reset and Run/Stop)
X2	Analogue inputs	S2	Terminating resistor CAN [CAN0] (120 Ohm)
X3	USB 2.0	S3	Terminating resistor RS-485 [COM2] (120 Ohm)
X4	Ethernet [ETH0] ¹	S11	Terminating resistor CAN [CAN1] (120 Ohm) (only version S05)
X5	USB 2.0	μSD	MicroSD card slot
X6	EtherCAT [ETH1], also configurable as Ethernet		

¹ Designations in []: CODESYS-designations of the connections

3.2 Scope of delivery and accessories

Scope of delivery

→ Device

Accessories

The following accessories are available as options H001 or separately via the order number.

Order number	Valid for	Remarks
S-02020105-0100	Compact HMI Pro 4 Compact HMI Pro 7 corresponds to H001	Plug kit: 1 x 12-pin plug-in connector for the digital inputs/outputs and power supply, Weidmüller BLZF 3.50/12/180, no. of rows: 1 1 x 6-pin plug-in connector for the analogue inputs, Weidmüller B2CF 3.50/06/180
S-02020105-0200	Compact HMI Pro 10 Compact HMI Pro 15 corresponds to H001	Plug kit: 1 x 12-pin plug-in connector for the digital inputs/outputs and power supply, Weidmüller BLZF 3.50/12/180, no of rows: 2 1 x 6-pin plug-in connector for the analogue inputs, Weidmüller B2CF 3.50/06/180
S-02020201-0100	Compact HMI Pro 4 Compact HMI Pro 7 (S01 and S02 corresponds to H001	1 x 2-pin plug connector for power supply Weidmüller BLZF 3.50/02/180, single row
S-02020201-0601	Compact HMI Pro 10 Compact HMI Pro 15	1 x 12-pin plug-in connector for the digital inputs/outputs and power supply, Weidmüller B2CF 3.50/12/180, no of rows: 2

3.3 Product features

3.3.1 Assembly

Devices from the Astraada One Compact HMI Pro series are designed for installation in a front panel or in a control cabinet in a rough industrial environment.

3.3.2 Processor

In its basic configuration, the device is equipped with an 800 MHz ARM® CPU with a Cortex™ A9 core. Customer-specific variants are available, which instead of a single core processor are equipped with a dual core or quad core processor.

3.3.3 Ethernet

The Astraada One Compact HMI Pro has 2 Ethernet interfaces with 10/100 Mbit/s. The first Ethernet interface is used for standard Ethernet connections. The TCP/IP and UDP/IP protocols permit flexible connections to visualization software, upstream control units and to the IT infrastructure. The second Ethernet interface is used as an EtherCAT master interface.

Other protocols available for the Ethernet interfaces: PROFINET, BACnet and Modbus.

3.3.4 USB

The USB host interface allows a wide range of peripherals to be connected to the device. This allows a USB thumb drive to be used for updating the application or for downloading data directly.



USB thumb drives with FAT/FAT32 formatting are supported.

If you require support for other USB formats, please contact our Technical Support team.

CAN interfaces

Compact HMI Pro (S03 – S05) devices are available in versions with 1 (S03 and S04) or 2 (S05) standard CAN interface which can be used at a speed of up to 1 Mbit/s.

Serial interfaces

The S04 and S05 variants of the Compact HMI Pro series have a combined serial interface (1x RS-485 or 1x RS-232).

Onboard analogue inputs/outputs

The device (S02 – S05) incorporates digital inputs/outputs and analogue inputs.

Additional interfaces

There is also a debugging interface located on the device which is accessible via a 3.5-mm jack plug with a special cable (contact Customer Services if necessary).

Real-time clock

A software interface permits the current time and date to be set and read on a real-time clock with battery back-up.

microSD card

The standard commercial microSD card interface (S03 – S05) allows data to be written to or read from memory cards.

Summary of features of Compact HMI Pro 4, Compact HMI Pro 7

Features depend on the S01-S05 version

- ARM® CPU with Cortex™-A9 single core (800 MHz; optional dual core or quad core)
- User program and data memory (RAM): 256 MB onboard
- User program memory (flash) 256 MB onboard
- 1 USB host interface (USB 2.0)
- Retain memory 100 kB
- 2 Ethernet 10/100 Base T interfaces (2nd interface: EtherCAT master interface)
- 1 or 2 CAN interfaces (expansion card)
- 2 serial interfaces (1x RS-232; 1x RS-485).
- 1 µSD card slot
- Onboard I/O
- Real-time clock

Summary of features of Compact HMI Pro 10 and 10 Pro 15

Features depend on the S01-S05 version

- ARM® CPU with Cortex™-A9 single core (800 MHz; optional dual core or quad core)
- User program and data memory (RAM): 512 MB onboard
- User program memory (flash) 512 MB onboard, up to 2 GB
- 2 USB host interfaces (USB 2.0)
- Retain memory 100 kB
- 2 Ethernet 10/100 Base T interfaces (2nd interface: EtherCAT master interface)
- 1 CAN interface or 2 CAN interfaces (expansion card, version S05)
- 2 serial interfaces (1x RS-232; 1x RS-485).
- 1 µSD card slot
- Onboard I/O
- Real-time clock

4 Assembly

4.1 Preparation for installation

The devices are intended for installation in a rectangular cut-out on a front panel. The support material must be rigid.

Prerequisites:

- The device must have a clear space of at least 20 mm all round at the rear, to allow sufficient air circulation.
- The max. surrounding air temperature in the control cabinet must not exceed 55°C, DualCore 50°C, during operation.
- The support material for the installation cut-out must be of the specified thickness (see installation cut-out) and must be flat and sufficiently stable.

NOTICE

Damage to the device!

Installation on uneven support material can lead to mechanical stresses and cracks in the front face or to malfunctioning of the touch screen.

- ▶ Make sure that the mounting points of the device are all in a common plane, with no more than maximum ± 0.5 mm variation.
-

4.1.1 Compact HMI Pro 4 dimensions

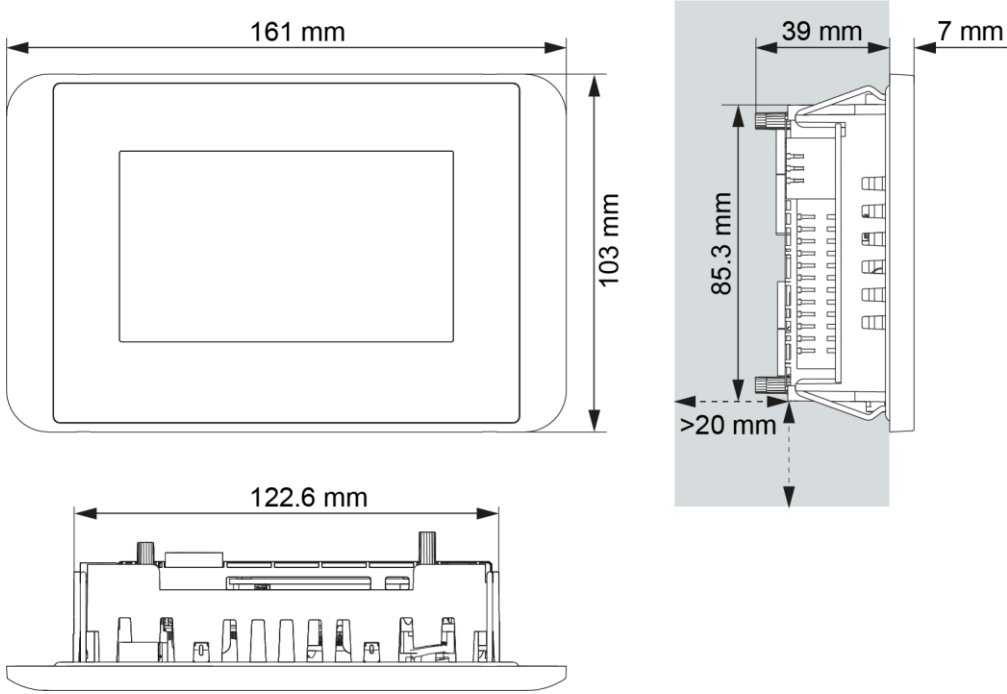

Fig. 4: Compact HMI Pro 4 dimensions

4.1.2 Compact HMI Pro 4 installation cut-out

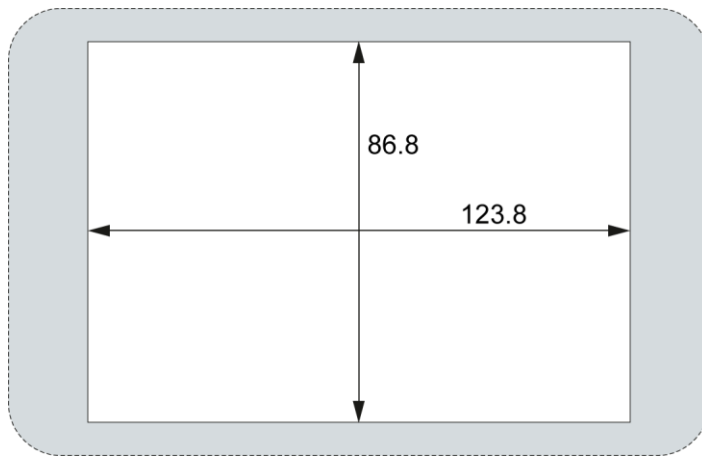



Fig. 5: DC2004 and ET2004 installation cut-out

- ▶ Cut a rectangular installation cut-out in the support material:
 - Height: 86.8 mm
 - Width: 123.8 mm
 - Max. corner radius: 3.0 mm

-  Optimum thickness of support material:
 - Protection rating IP65 with twist-lock catches: only at 1.5–3.0 mm
 - Optimum: 1.5–2.0 mm
 - Max. 3.0 mm

4.1.3 Compact HMI Pro 7 dimensions

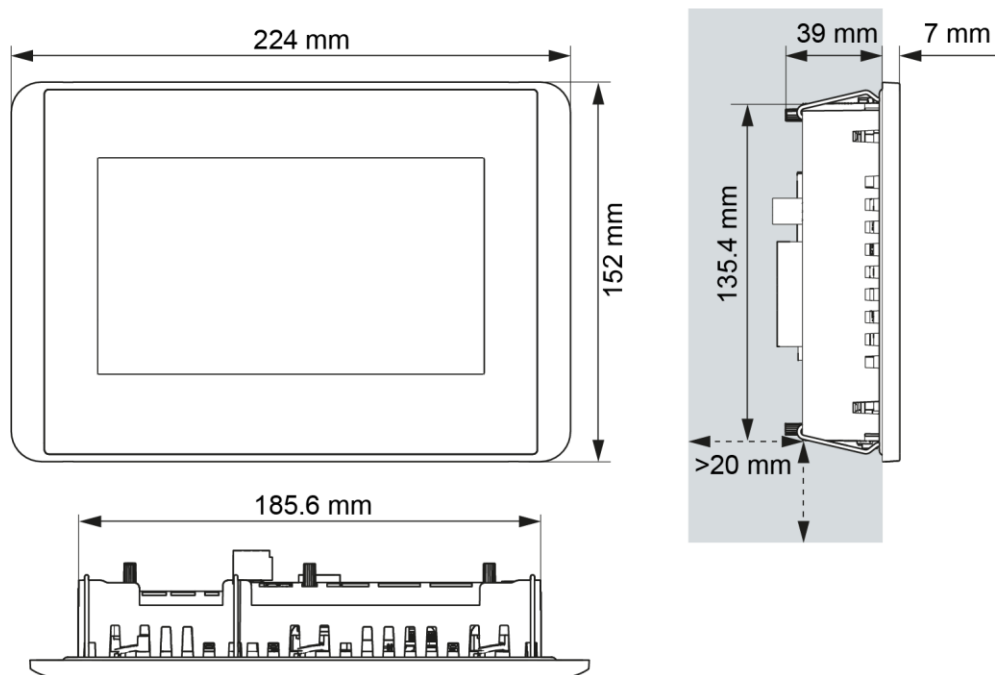

Fig. 6: Compact HMI Pro 7 dimensions

4.1.4 Compact HMI Pro 7 installation cut-out

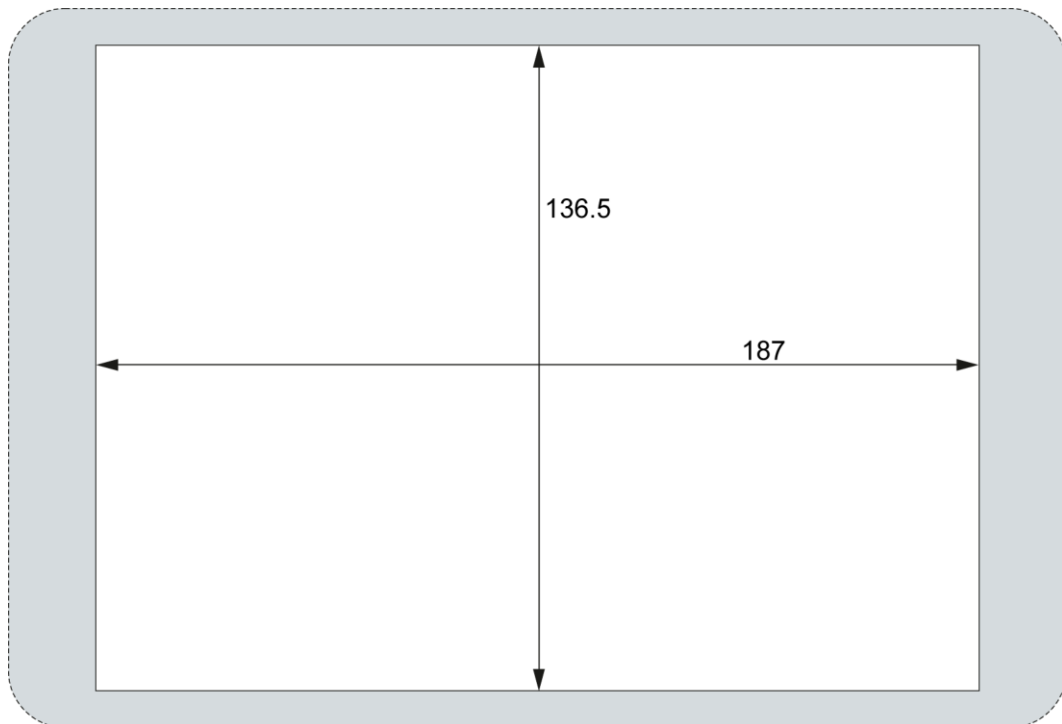



Fig. 7: Compact HMI Pro 7 and ET Pro 7 installation cut-out

- ▶ Cut a rectangular installation cut-out in the support material:
 - Height: 136.5 mm
 - Width: 187.0 mm
 - Max. corner radius: 3.0 mm

-  Optimum thickness of support material:
 - Protection rating IP65 with twist-lock catches: only at 1.5–3.0 mm
 - Optimum: 1.5–2.0 mm
 - Max. 3.0 mm

4.1.5 Compact HMI Pro 10 dimensions

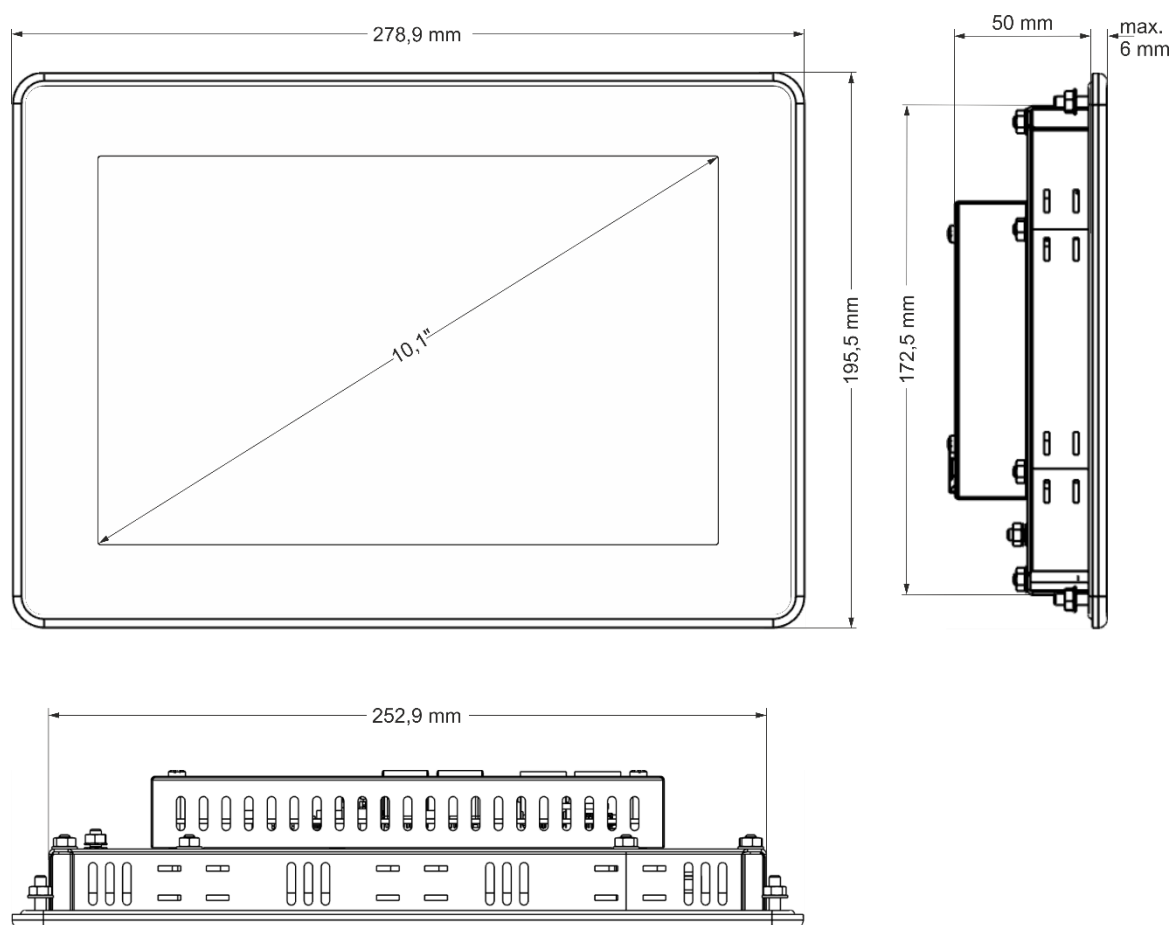

Fig. 10: Compact HMI Pro 10 dimensions

4.1.6 Compact HMI Pro 10 installation cut-out

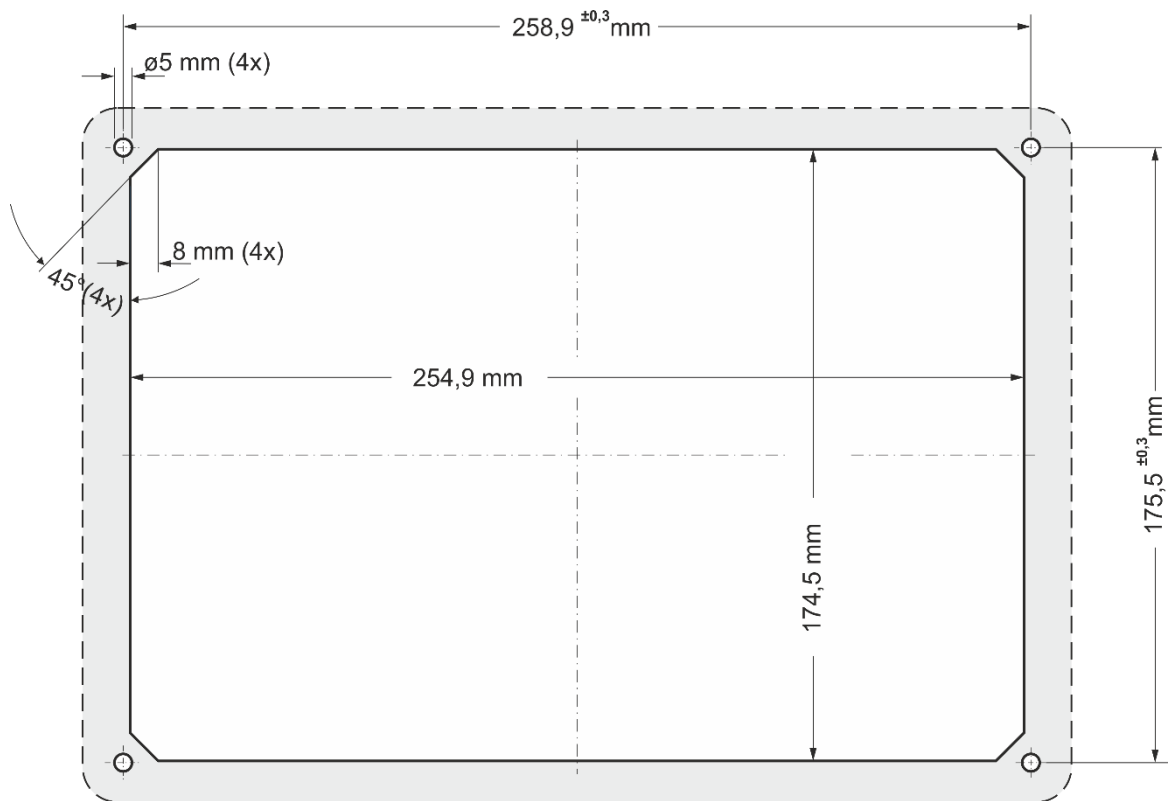

Fig. 11: Compact HMI Pro 10 and ET-Pro 10 installation cut-out

- ▶ Cut a rectangular installation cut-out in the support material:
Height: 174.5 mm
Width: 254.9 mm
Max. corner radius: 3.0 mm
- i** Optimum thickness of support material:
Protection rating IP65 with additional clamps: only at 1.5–3.0 mm
Optimum: 1.5–3.0 mm
Max. 4.0 mm

4.1.7 Compact HMI Pro 15 dimensions

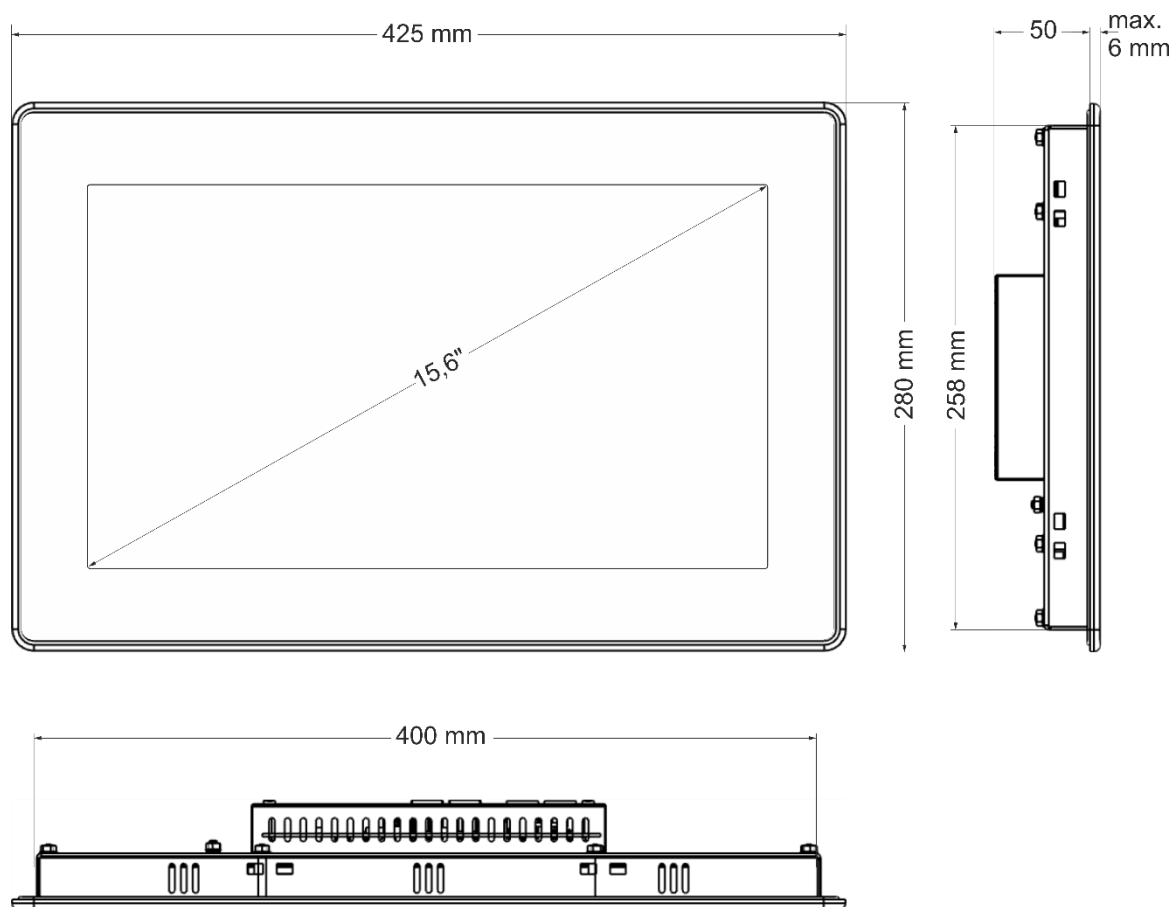

Fig. 12: Compact HMI Pro 15 dimensions

4.1.8 Compact HMI Pro 15 installation cut-out

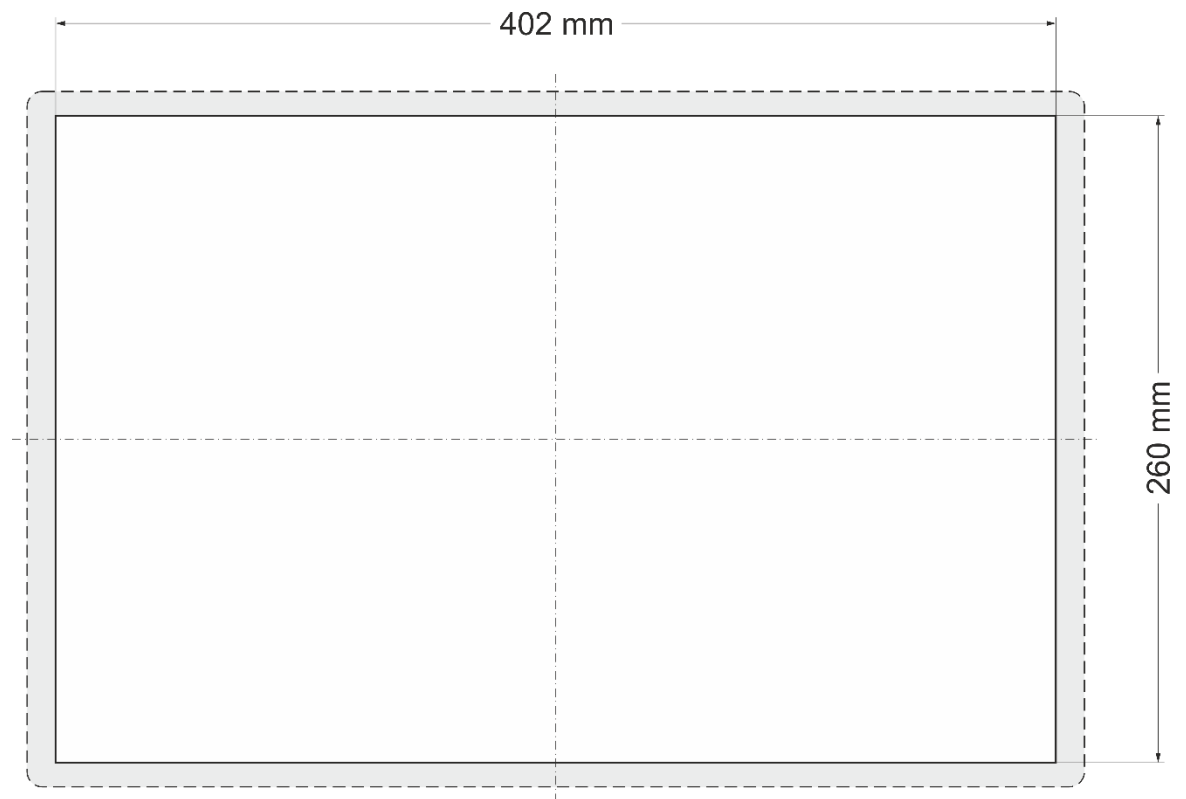

Fig. 13: Compact HMI Pro 15 and ET-Pro 15 installation cut-out

- ▶ Cut a rectangular installation cut-out in the support material:
Height: 260 mm
Width: 402 mm
Max. corner radius: 3.0 mm



Thickness of support material:
Optimum: 2.0–3.0 mm
Max. 4.0 mm

4.2 Installation

4.2.1 Compact HMI Pro 4/7 installation

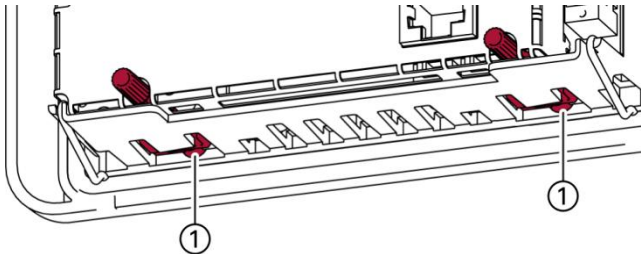

Fig. 14: Opening the twist-lock catches

- 1st Device with twist-lock catches: make sure that the twist-lock catches are turned anti-clockwise to the limit and are fully open (1).

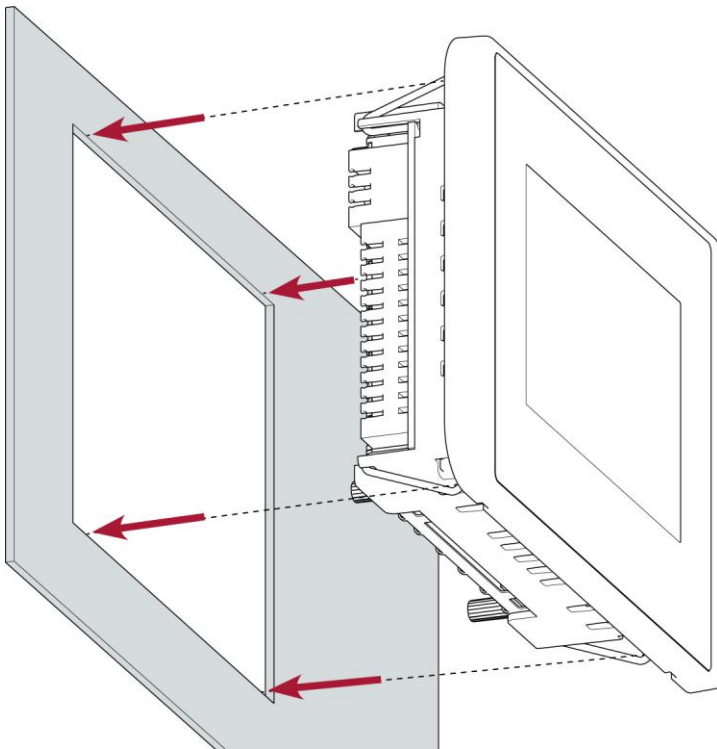

Fig. 15: Installation in an installation cut-out, example with 4 fastening clips

- 2nd Making sure the alignment is correct, push the device evenly into the installation cut-out until the 2 or 3 fastening clips snap into place.

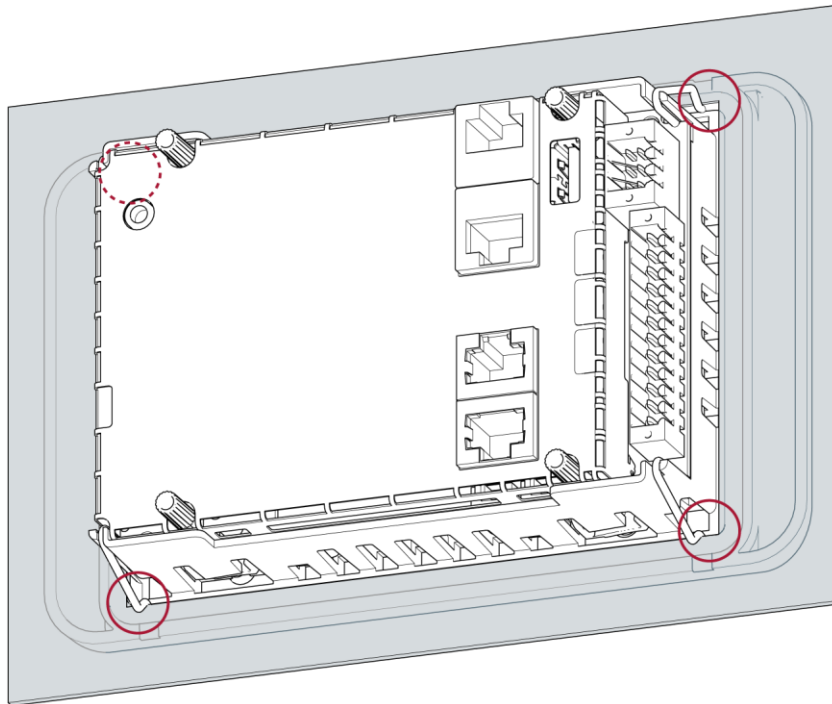

Fig. 16: Device clipped into place in the installation cut-out, example with 4 fastening clips

- 3rd Make sure that the device is lying flush all round.
- 4th Device with twist-lock catches: Use a T9x50 screwdriver to tighten the twist-lock catches to a maximum of 0.4 Nm.



The protection rating IP65 on the front face is only achieved when the twist-lock catches are used correctly.

4.2.2 Compact HMI Pro 10 installation

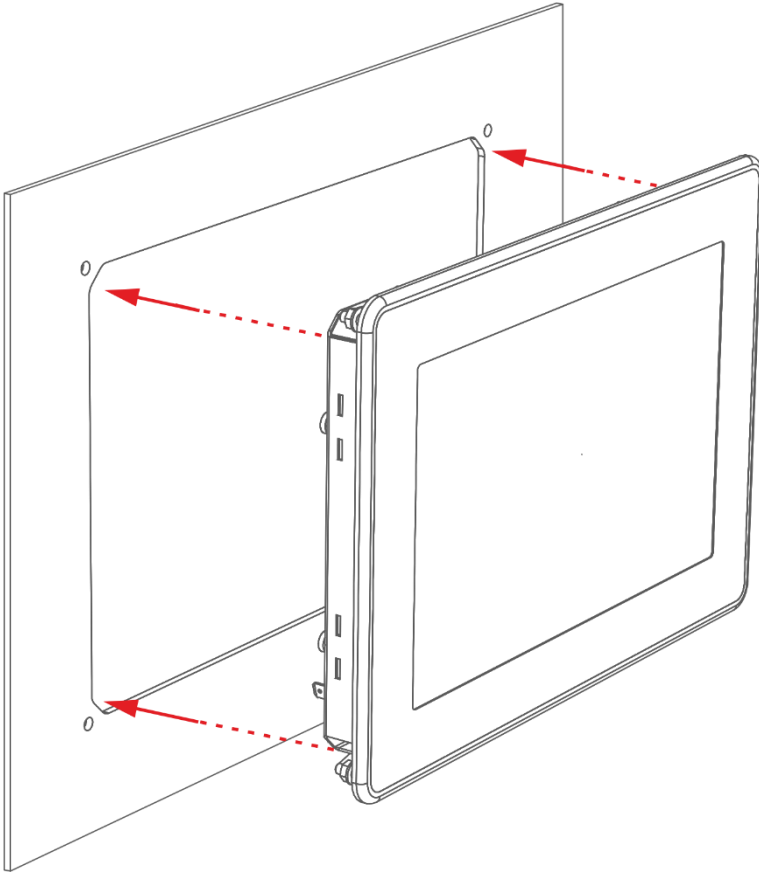

Fig. 18: Installing in the installation cut-out

Prerequisites:

→ The tensioning clamps are not attached to the device.

1st Making sure the alignment is correct, push the device evenly into the installation cut-out.

NOTICE

Damage to the device!

If the device is mounted carelessly, it may fall out of the installation cut-out or get damaged.

- ▶ Do not tilt the device.
 - ▶ Secure the device against falling down until the clamps are attached.
-

2nd Make sure that the device is lying flush all round.

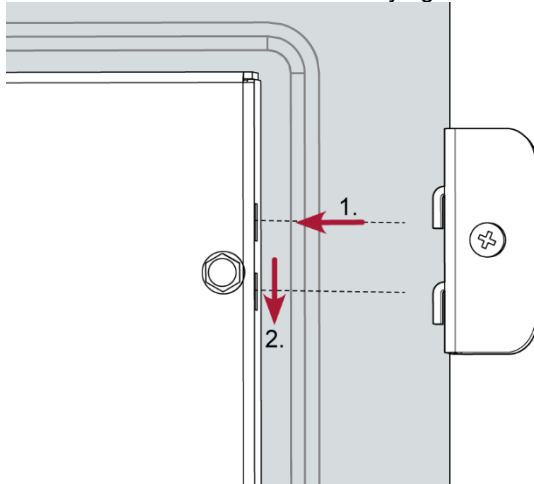

Fig. 19: Hooking in the tensioning clamps (at the rear)

3rd Attach the device with 2 tensioning clamps: Hook in the tensioning clamps diagonally opposite each other on the cover and tighten the screws slightly.

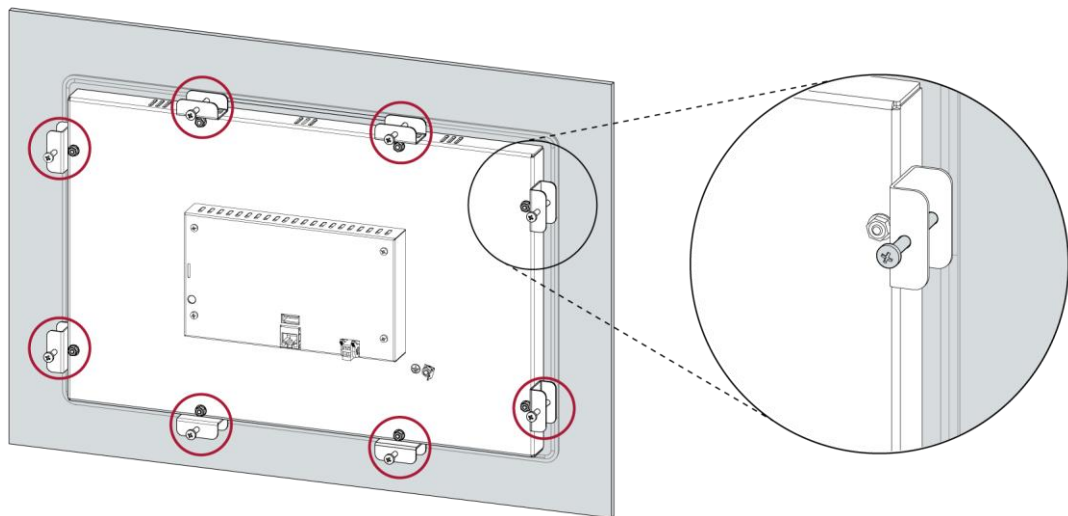

Fig. 20: Tightening the tensioning clamps

4th Hook in the remaining 6 tensioning clamps in the cover and tighten all 8 screws evenly.

4.2.3 Compact HMI Pro 15 installation

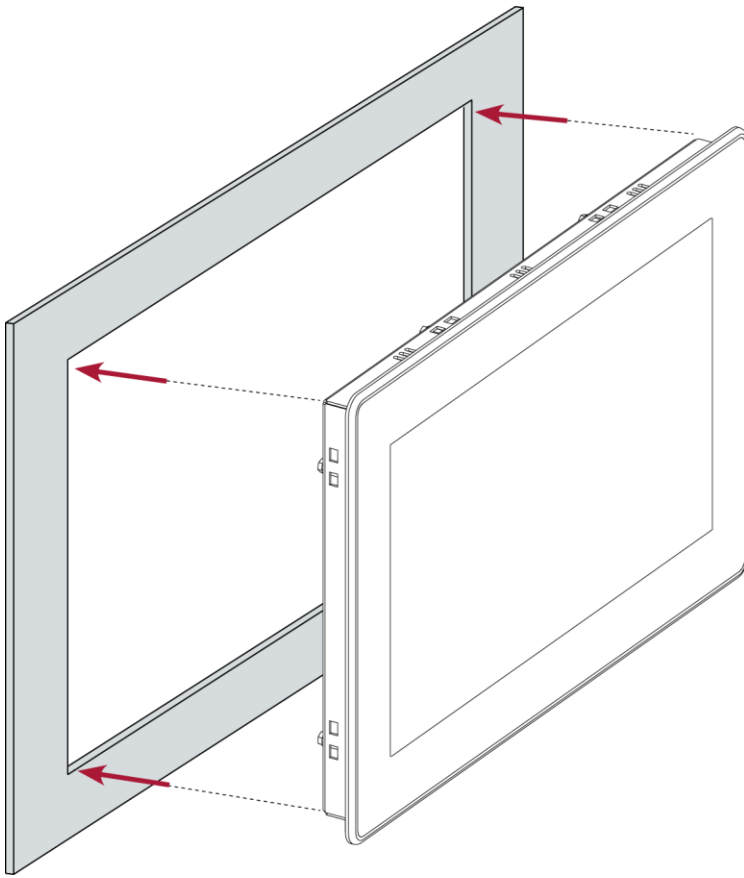

Fig. 21: Installing in the installation cut-out

Prerequisites:

→ The tensioning clamps are not attached to the device.

1st Making sure the alignment is correct, push the device evenly into the installation cut-out.

NOTICE

Damage to the device!

If the device is mounted carelessly, it may fall out of the installation cut-out or get damaged.

- ▶ Do not tilt the device.
 - ▶ Secure the device against falling down until the clamps are attached.
-

2nd Make sure that the device is lying flush all round.

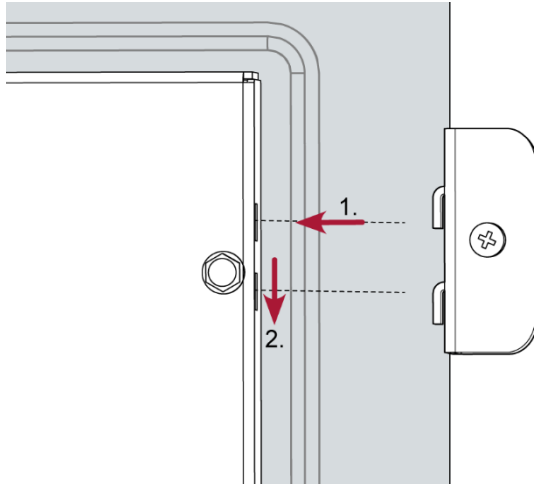

Fig. 22: Hooking in the tensioning clamps (at the rear)

3rd Attach the device with 2 tensioning clamps: Hook in the tensioning clamps diagonally opposite each other on the cover and tighten the screws slightly.

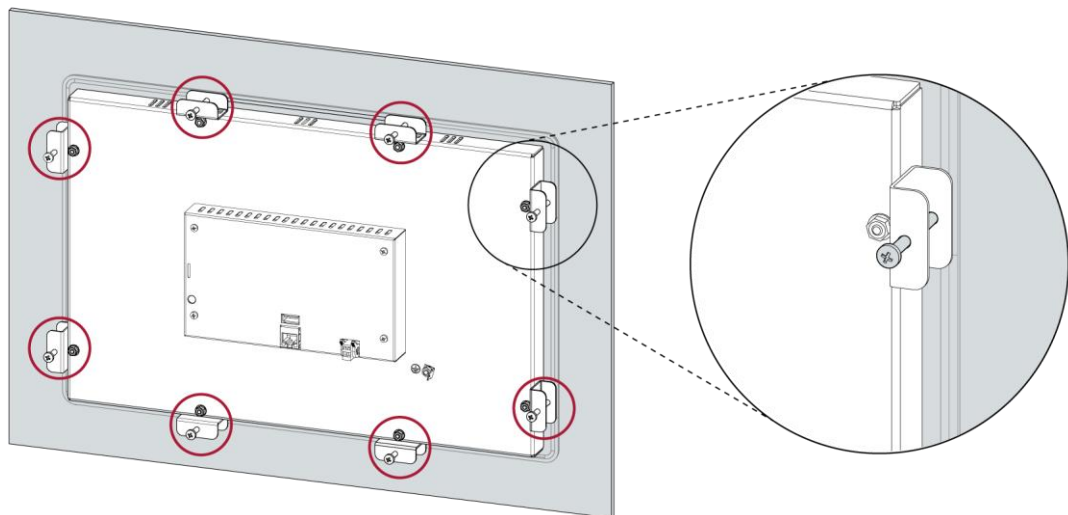

Fig. 23: Tightening the tensioning clamps

4th Hook in the remaining 6 tensioning clamps in the cover and tighten all 8 screws evenly.

5 Connection

WARNING

Uncontrolled and unpredictable operational behaviour!

The failure of certain components in electronic control systems may result in uncontrolled and unpredictable operational behaviour.

- ▶ All types of failure and the associated fuse systems are to be taken into account at system level.
 - ▶ Follow the automation system manufacturer's instructions.
-

5.1 Power supply

The device is powered by an external 24 V DC power supply.

- ▶ Before plugging in the device, make sure that the external power supply meets the required specifications (type K to DIN EN 61131-2).

External power supply (24 V DC)

Supply voltage	+24 V DC SELV (-15% / +20%)
AC voltage component	Max. 5% The DC voltage level must not fall below 20.4 V.
Power consumption	Compact HMI Pro 4: Total max. 3 A at+24 V DC (2,7 A digital outputs), Compact HMI Pro 7: Total max. 3 A at+24 V DC (2,7 A digital outputs), Compact HMI Pro 10: Total max. 3,5 A at +24 V DC (2,7 A digital outputs), Compact HMI Pro 15: Total max. 3,6 A at +24 V DC (2,7 A digital outputs)
Power buffering	10 ms

Internal power supply

A power supply for the system electronics for an input voltage of 24 V DC (-15% / +20%) is integrated into the device. The power supply unit has built-in reverse polarity protection and surge current protection (1.2 A).

Installation

- ▶ All connections and cables should be set up in a way that prevents interference and capacitive interference to the device.
- ▶ Make sure that the current and voltage resistance of the supply cables are sufficient.

5.1.1 Connecting the power supply

⚠ CAUTION

Live parts!

- ▶ Before starting any work on the device, switch off all power supplies, including those of connected peripherals.

5.1.2 Compact HMI Pro 4/7 power supply

- ▶ Connect the power supply to plug X1 according to the following table. (only for version S03 – S05)

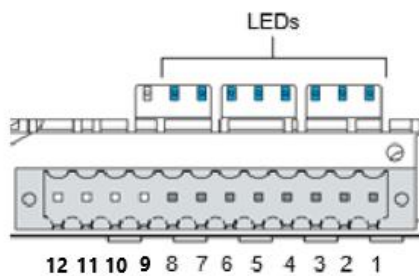

Fig. 24: Power supply to the Compact HMI Pro 4/7 with power LED (only version S03 – S05)

Compact HMI Pro 4/7 power supply plug X1 (only version S03 – S05)		
Pin	Des.	Assignment
1-8	I/O	digital inputs and outputs (see “ Digital inputs and outputs
9	L1+ 24 V	Feed to digital output (max. 2.7 A) for I/O
10	L0+ 24 V	Power supply 24 V DC (-15%/+20%) Astraada One Compact HMI Pro 4 S03 – S05 (PLC internal): max. 0.3 A Astraada One Compact HMI Pro 7 S03 – S05 (PLC internal): max. 0.3 A Astraada One Compact HMI Pro Rack 7 S03 – S05 (PLC internal): max. 0.3 A
11	L0+ 24 V	Power supply 24 V DC (-15%/+20%) Astraada One Compact HMI Pro 4 S03 – S05 (PLC internal): max. 0.3 A Astraada One Compact HMI Pro 7 S03 – S05 (PLC internal): max. 0.3 A Astraada One Compact HMI Pro Rack 7 S03 – S05 (PLC internal): max. 0.3 A
12	GND	–

The following counterparts have been tested for the SL-SMT 3.5 plug-in connector (Weidmüller), and may be used with the device:

→ BLZF 3.50/12/180

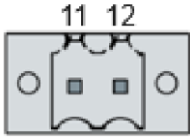

Fig. 25: Power supply to the Compact HMI Pro 4/7 X10 (only for version S01 and S02)

Compact HMI Pro 4/7 power supply plug X10 (only for version S01 and S02)

Pin	Des.	Assignment
11	L0+ 24 V	Power supply 24 V DC (-15 %/+20 %) Astraada One Compact HMI Pro 4 S01 and S02 (PLC internal): max. 0.3 A Astraada One Compact HMI Pro 7 S01 and S02 (PLC internal): max. 0.3 A
12	GND	-

The following counterparts have been tested for the SL-SMT 3.5 plug-in connector (Weidmüller), and may be used with the device:

→ BLZF 3.50/02/180

5.1.3 Compact HMI Pro 10/15 power supply

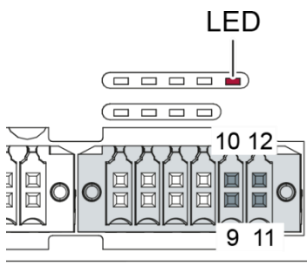

Fig. 26: Power supply to the Compact HMI Pro 10/15 plug X1 with power LED

► Connect the power supply to plug X1 according to the following table.

Compact HMI Pro 10/15 power supply plug X1

Pin	Des.	Assignment
1-8	I/O	digital inputs and outputs (see “ Digital inputs and outputs)
9/12	L0+ 24 V	Power supply 24 V DC (-15%/+20%) Astraada One Compact HMI Pro 10 (PLC internal): max. 0.8 A Astraada One Compact HMI Pro 15 (PLC internal): max. 0.9 A
10	L1+ 24 V IO	Feed to digital output (max. 2.7 A for) for I/O

The following counterparts have been tested for the S2C-SMT 3.5 plug-in connector (Weidmüller), and may be used with the device:

→ B2CF 3.50/12/180

5.2 Data connections

5.2.1 Block diagram

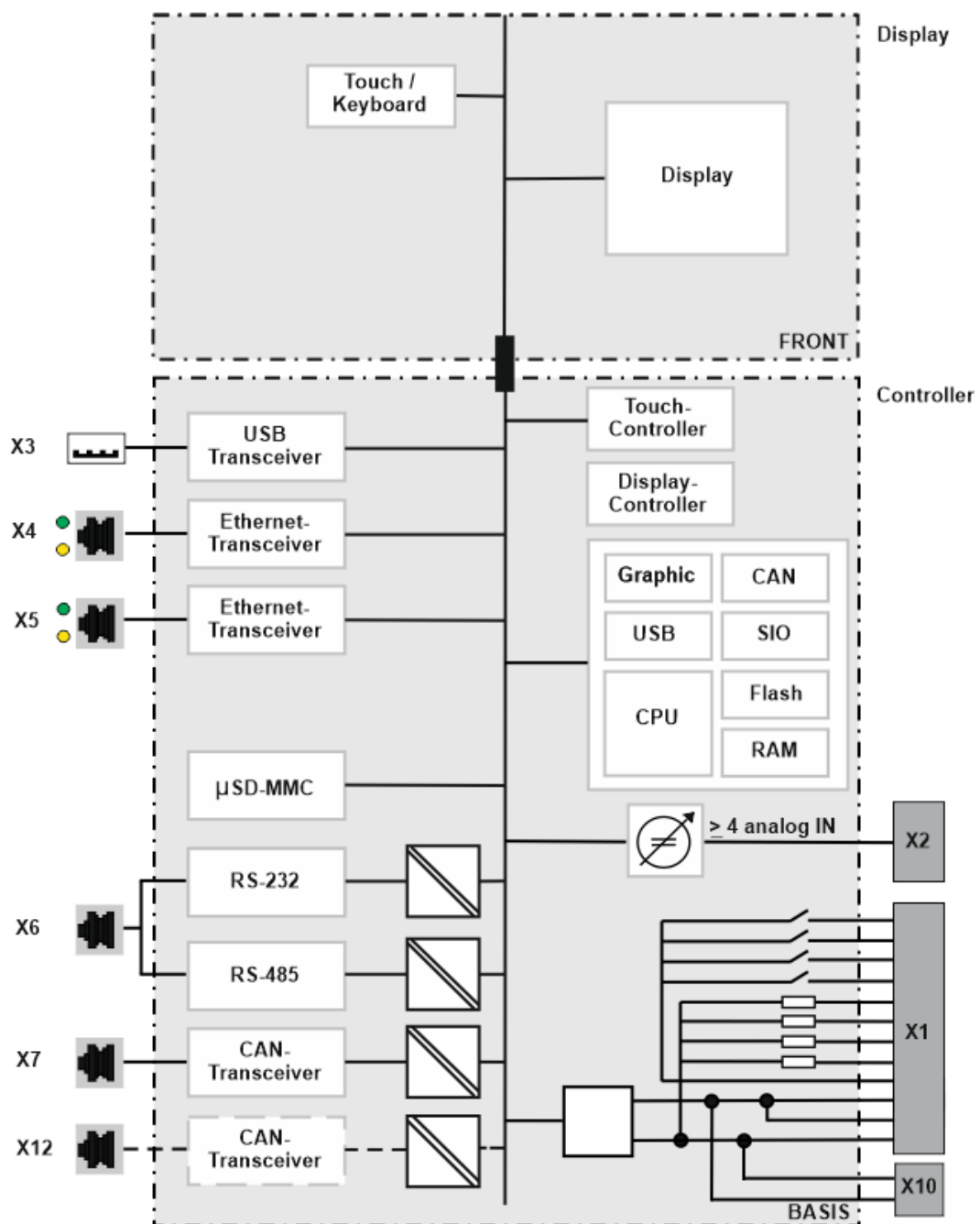

Fig. 27: Block diagram of Compact HMI Pro

5.2.2 Digital inputs and outputs (not all modules)

The digital outputs are positive switching 24 V outputs with an output current of max. 500 mA. They have a common reference potential (GND) with the supply voltage.

NOTICE

Damage to the inputs or the device!

Voltages above ± 32 V can damage the inputs or the device.

- ▶ Do not apply a voltage exceeding ± 32 V to the inputs.

The digital inputs are positive switching inputs, type 1 or 3 (IEC 61131-2) They are designed for nominal input voltages of 24 V. The input signals are transmitted internally on a cyclical basis for process data processing. An open input is interpreted as static 0 (LOW). The inputs also have a common reference potential (GND).

The following counterparts have been tested for the S2C-SMT 3.5 plug-in connector (Weidmüller), and may be used with the device:

- Connector BLZF 3.50/12/180 no of rows: 1 or connector B2CF 3.50/12/180 no of rows: 2

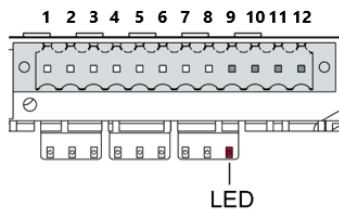

Fig. 28: Digital input and outputs, Compact HMI Pro plug of rows 1 X1 with LEDs 1 to 8

Digital inputs and outputs, connector X1 of rows 1

Pin	Des.	Assignment
1	DI 1 / C1	digital input/counter input 1
2	DI 2 / C2	digital input/counter input 2
3	DI 3 / C3	digital input/counter input 3
4	DI 4 / C4	digital input/counter input 4
5	DO 1	digital output 1
6	DO 2	digital output 2
7	DO 3	digital output 3
8	DO 4	digital output 4
9...12	-	Power supply (see "Power supply")

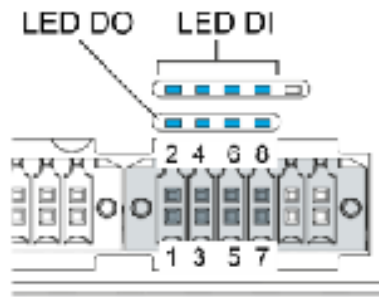

Fig. 29: Digital input-and outputs, Compact HMI Pro plug of rows 2 X1 with LEDs 1 to 8

Digital inputs and outputs, connector X1 of rows 2

Pin	Bez.	Belegung
1	DO 1	digital output 1
2	DI 1	digital input / counter input 1
3	DO2	digital output 2
4	DI 2	digital input / counter input 2
5	DO 3	digital output 3
6	DI 3	digital input / counter input 3
7	DO 4	digital output 4
8	DI 4	digital input / counter input 4

Data from the digital outputs		
Feature	Value	Description
Type of output	Semiconductor	Non-storing, current supplying (positive switching)
Protective circuit for inductive loads	41 V clamping voltage (typ.) compared to +24 V	Fast de-excitation (must be provided externally)
Status display	Yes	One orange LED per output Lights up at logical 1
Overload protection	Yes	In the case of thermal overload, auto-resetting
Short-circuit protection response threshold	Yes	Electronic current limitation: typ. 7 A The current is limited electronically. Activation of the short-circuit protection results in thermal overload and tripping of the thermal overload protection. Permissible limit values starting from cold state: max. 10,000 short circuits, total duration max. 500 hours.
Status in unsafe operating conditions	Logical 0	If the supply voltage is insufficient and the control system is started up or shut down, the outputs are set to logical 0.
Output delay "0" after "1"	typ. 1 ms	–
Output delay "1" after "0"	typ. 1 ms	–
Output capacitance	< 20 nF	–
Rated voltage	+24 V DC	–
Voltage drop (at rated current)	< 0.1 V	–
Rated current at "1" signal	0.5 A	–
Total current of all outputs	max. 2 A	–
Parallel switching of two outputs	max. 1 A	Maximum permissible value with a logical connection to increase power

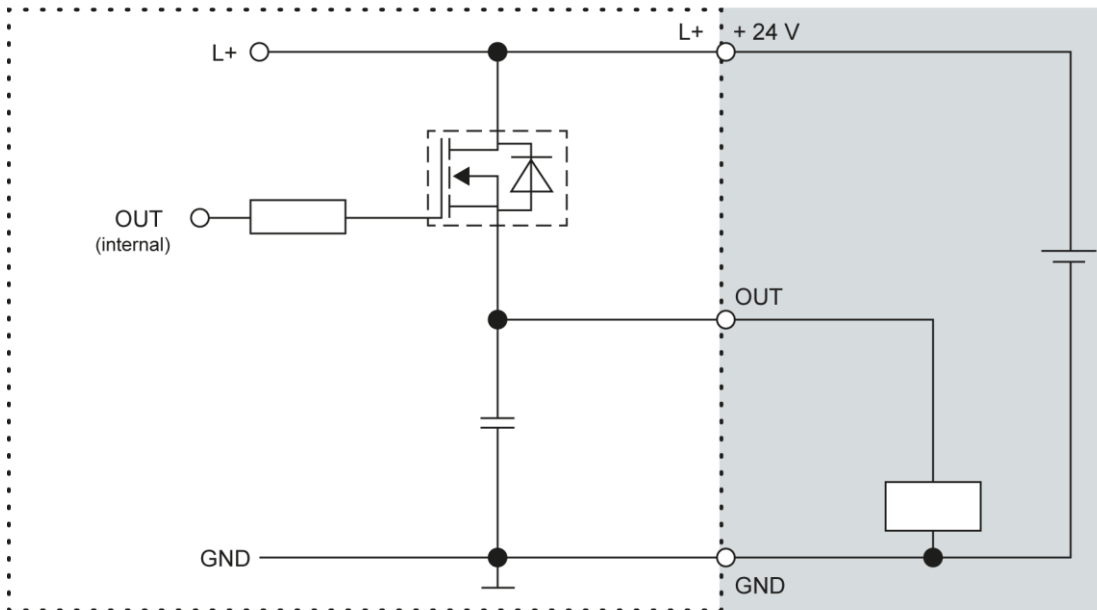

Fig. 30: Circuit diagram of the principles of positive switching, output

Data from the digital inputs		
Feature	Value	Description
Type of input	Type 1, 3	Acc. to IEC 61131-2 Current consuming (positive switching)
Cable length	max. 30 m	For unshielded connection cables Cables over 30 m in length must be shielded.
Cable cross-section in the control cabinet	0.14–1.5 mm ² (26-16 AWG)	Aim for plug connector limits to UL specifications.
Field wiring	comply with regulations and standards	Comply with all applicable local regulations and the requirements of DIN EN 61131-2.
Rated load voltage	24 V DC (SELV)	–
Delay time	1 ms	Applies to transitions from 0 to 1 and from 1 to 0
Signal evaluation	cyclical	Depends on the cycle time set in the programming system
Protection against reverse polarity	Yes	–
Potential isolation	No	–
Status display	Yes	One yellow LED per input Lights up at logical 1

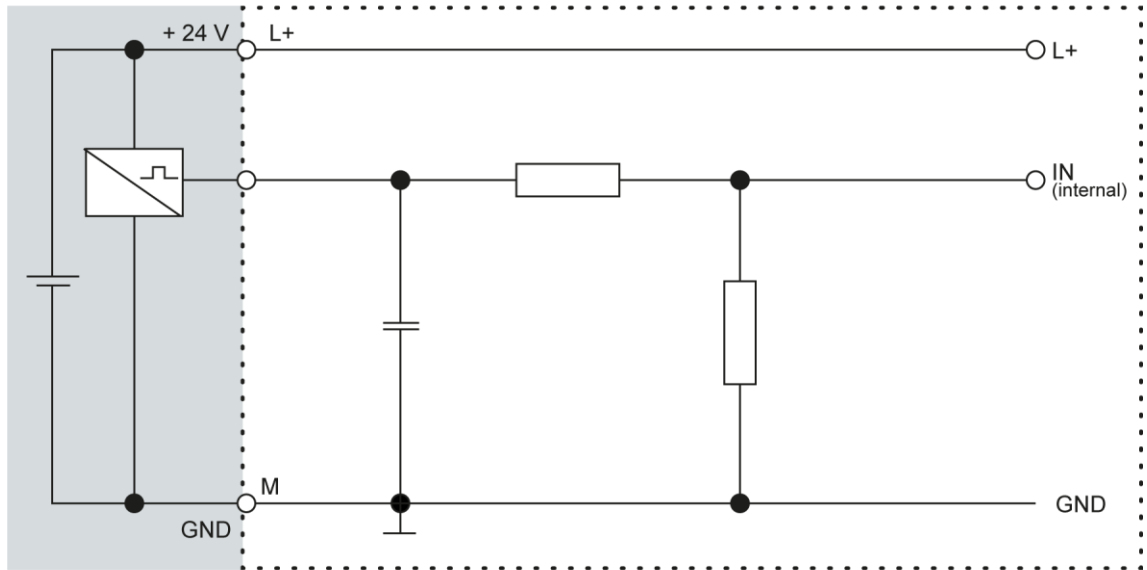

Fig. 31: Circuit diagram of the principles of positive switching, input

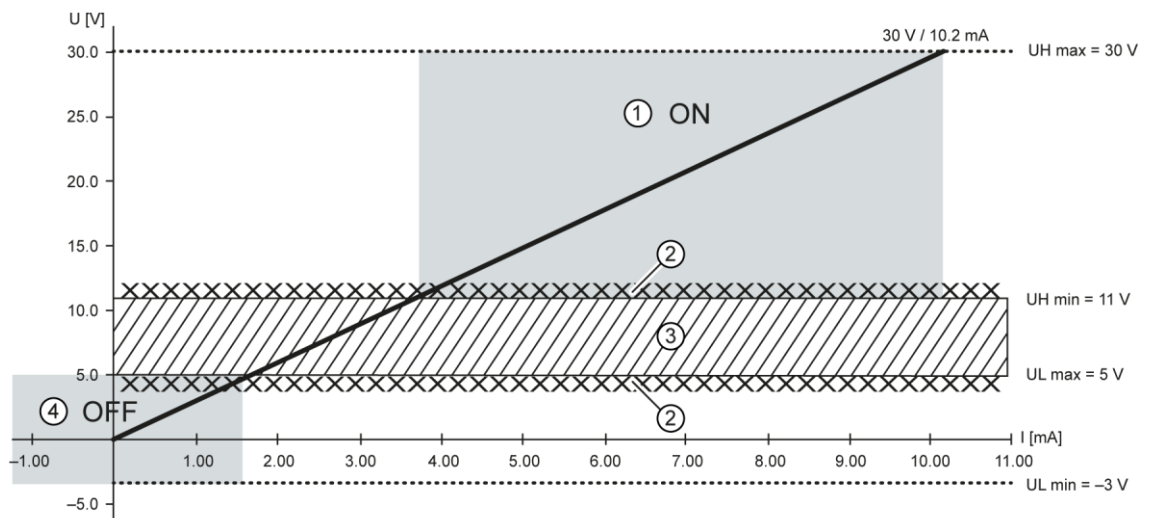

Fig. 32: Operating ranges of digital inputs (type 1/3)

No.	Designation	No.	Designation
1	"ON" range	3	Transition range
2	Signal-to-noise ratio < 1 V	4	"OFF" range

5.2.3 Counting inputs (C)

The 4 digital inputs can also be used as counter inputs (C1-C4).
can be enabled by licensing (also possible later).

The counter inputs C1-C4 have a fast filter; the unipolar inputs I5-I16 have hysteresis. The counter inputs are connected to the signals of the other unipolar inputs. There is no changeover switching.

Available options for the counter inputs:

- Up/down counter
- Pulse/direction counter
- Quadrature decoder

One of the counter inputs may alternatively be used as a capture input. This configuration requires 3 inputs (partially as CNT input or CAPT input). The edges for up, down or pulse may be set to falling and/or rising edge.

Direction: High = up; low = down

Examples for counters: up/down; pulse/direction; encoder (A/B)

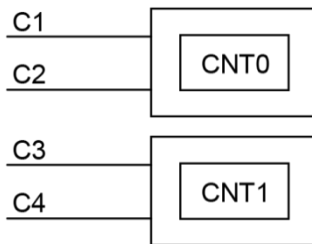

Fig. 33: Counter up/down or pulse/direction

Pin	Designation	Pin	Designation
C1	Up, pulse, A (CNT0)	C3	Up, pulse, A (CNT1)
C2	Down, direction, B (CNT0)	C4	Down, direction, B (CNT1)

Examples for counters: capture input or Z input

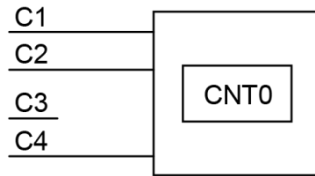

Fig. 34: Counter with capture input

Pin	Designation	Pin	Designation
C1	Up, A (CNT0)	C3	–
C2	Down, B (CNT0)	C4	Capture (rise), Z (CNT0)

Counter CNT1 is not available in this configuration.

Data from the counter inputs

Counter inputs		
Function	Value	Description
Number of counters	2	–
Signal voltage	(1): DC 15-28 V (0): DC -3-3 V	Pulse width at the valid level for at least 1 µs
Max. frequency: signal counter	500 kHz 1 counts/s	For 100 kHz see specific installation information. At the maximum counter frequency, the signal transmitter must ensure an edge steepness of at least 20 V/µs.
Min. pulse width	1 µs	Per level
Counter resolution	32 bit	–
Internal pull-up	3 kΩ	–

Installation information

- The counter inputs must be connected with shielded cables.
- Supply voltage (24 V DC; GND) and the signals of the transmitters must go through the same cable.
- The PLC and the transmitter must use the same power supply.

5.2.4 Analogue inputs (not all modules)

Basic considerations for connecting analogue inputs

- An analogue input channel always consists of two connections: AI (U) or AI (U/T) and AGND.
- The AI (U/T) channels can measure either voltages (U) or evaluate PT100(0) sensors.
- The AI (U) channels can measure voltages or be used for compensation of the line resistances for PT100(0) measurements (3-wire measurement).
- The Earth/Ground/GND lead of a voltage sensor or temperature sensor connected to an analogue input may only be connected to AGND (not to GND or PE (equipotential)).
- Different AGNDs (e.g. on one terminal strip) may not be connected together.
- AGNDs may not be connected to the general GND of the control cabinet or to the "M" on the control cabinet (GND and AGND are already connected within the control cabinet via a special filter).
- AGNDs may not be connected directly to the PE conductor of the machine or system
- Long cables and wires with a small cross-section lead to voltage drops and deviations in PT100(0) measurements (due to resistivity). These unavoidable deviations must be taken into account when planning the wiring.
- To avoid interference, analogue I/O wires must be kept separate from digital signals and power cables.
- Screened cables are advisable for all analogue I/Os. The screen is connected to the sensor or encoder and in the control cabinet or near the controller.

The following counterparts have been tested for the S2C-SMT 3.5 plug-in connector (Weidmüller), and may be used with the device:

Weidmüller B2CF 3.50/06/180(F) SN BK

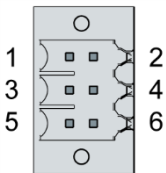

Fig. 35: Analogue inputs X2

Analogue inputs X2			
Pin	Assignment	Pin	Assignment
1	AI1 (U/T)	2	AI3 (U/T)
3	AGND	4	AGND
5	AI2 (U)	6	AI4 (U)

Data from analogue inputs

Data from analogue inputs		
Feature	Value	Description
Cable length	max. 30 m	Applies to unshielded connection cables. Cables over 30 m in length must be shielded.
Modulation method	Delta-sigma modulation	–
Shared points between the channels	AGND reference	–
Clamp arrangement	Shielding on common AGND pins	–
Sampling duration/rate for measuring values	1 ms	A reading is taken from each input channel every millisecond regardless of how many channels are actually in operation
Sampling rate AI-PT operating mode	250 ms	In AI-PT operating mode, calculations are carried out according to the millisecond sampling rate. A new value is available in the user program every 250 ms.

Digital filtering		
Possible filter settings	Time range for averaging	Time range for averaging AI-PT operating mode
0	1 ms	0.25 s
10	10 ms	2.5 s
100	100 ms	25 s
1,000	1,000 ms (1 s)	250 s

If filtering is active, an average is calculated for the set time range. However, a value is still issued during the sampling rate interval. For example, if the filter is set to 1,000, the average of the measurements for the last 1,000 ms / 1,000 measurements is issued each millisecond (or, in the case of AI-PT operating mode, every 250 ms, the average from the last 250 ms / 1,000 measurements).

The filtering can be activated and configured using CODESYS V3. The sampling rate is constant. It can only be filtered with a whole multiple of the sampling rate.

Operating modes for the analogue inputs

NOTICE

Damage to channel

High voltages can damage analogue channels, stopping them from working correctly.

- ▶ Ensure the input voltage does not exceed ± 30 V.

Operating mode: voltage input AI (U)

Feature	Value	Description
Connections per input	–	AI (U/T) and AGND or AI (U) and AGND; connect shield to AGND.
Measuring range	-10 - +10 V	–
Input impedance in signal range	100 k Ω	between AI (U/T) and AGND or between AI (U) and AGND value applies when the channel is switched on or off
Max. errors at 25°C	$\pm 0.25\%$ (± 0.50 mV)	–
Temperature coefficient	± 40 ppm/K (± 0.4 mV/K)	–
Digital resolution	24 bit	–
Data format in application program	32 bit real	(floating-point number) in millivolts (mV)
Maximum permissible permanent overload	Max. ± 30 V compared to AGND	± 30 V = max. voltage on AI channel
Value of least significant bit	1.2 μ V	–
Output of digital value in case of overload	–	If a voltage of ± 10 V is applied to an AI (U), a plausible value is still given up to approx. ± 15 V. The specified accuracy is only valid for the range -10 to +10 V. When applying voltages above +15 V or below -15 V, a fault bit (FAULTN/FAULTP) is set in the process image which can be read by the user program.
Input type	–	Asymmetrical voltage metering (single-ended)
Reference potential	AGND	–
Dynamic properties		

Operating mode: voltage input AI (U)		
Feature	Value	Description
Analogue filtering	Second-grade low-pass filter; cut-off frequency 650 Hz	–
Greatest temporary deviation during electrical error testing according to IEC 61131-2	1% of measuring range	–

Operating mode: temperature inputs AI-PT		
Feature	Value	Description
Connections per input	–	Sensor connection between AI (U/T) and AGND (if applicable, an additional AI (U) channel is used for 3-wire measurement)
Possible sensors	PT100 and PT1000 acc. to EN 60751	Accuracy class AA, A, B and C platinum sensors may be used
Measuring range	-40 - +200°C	–
Measuring current (RMS)	0.3 mA	–
Conversion time	250 ms	–
Max. errors at 25°C	±2,100 ppm (±0.5°C)	–
Temperature coefficient	±50 ppm/K (±0.012°C/K)	–
Digital resolution	24 bit	–
Data format in application program	2 × 32 bit real	(floating-point number) in Ohms (Ω) and degrees Celsius (°C)
Linearisation	–	The value in degrees Celsius is calculated from the resistance value and linearised (6th degree polynomial)
Input type	–	2-wire measurement or 3-wire measurement
Reference potential	AGND	–
Dynamic properties		

Operating mode: temperature inputs AI-PT

Feature	Value	Description
Analogue filtering	Second-grade low-pass filter; cut-off frequency 650 Hz	–
Greatest temporary deviation during electrical error testing according to IEC 61131-2	1% of measuring range	–

Voltage input AI (U)

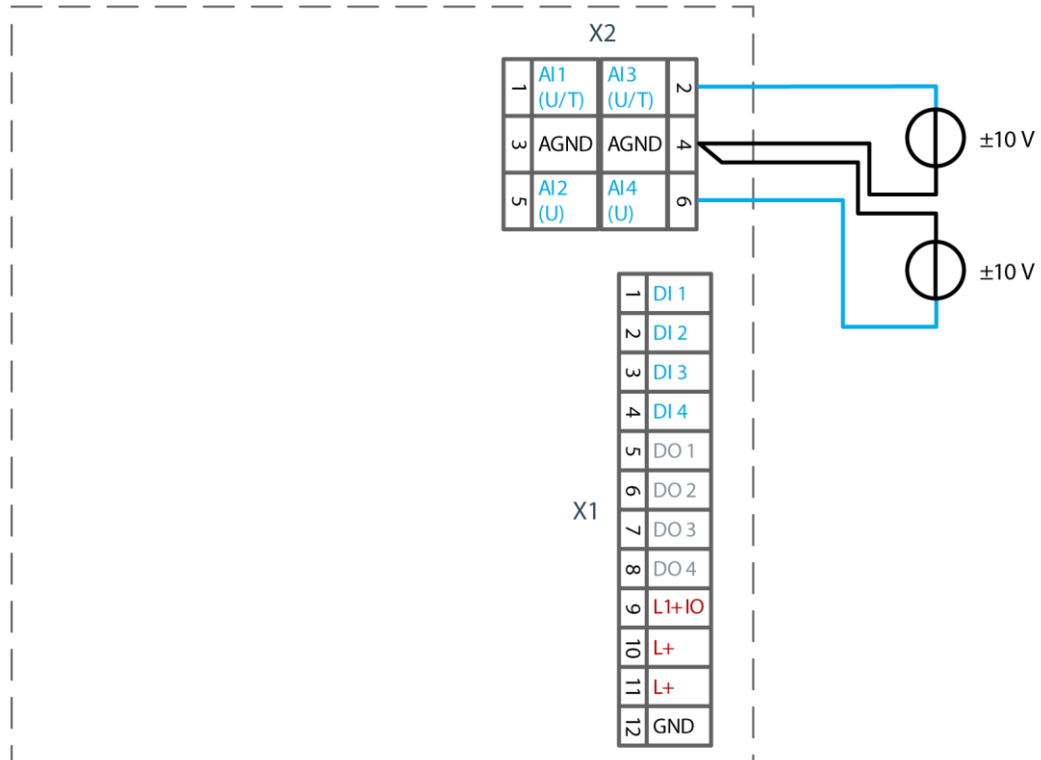

Fig. 36: Connection example: voltage input

- ▶ Only use the corresponding AGND for each voltage input.
- ▶ Do not connect AGNDs from different channels.
- ▶ AGNDs from different channels must always be connected separately to plug X1.
- ▶ Do not connect to the common GND. The required connections can already be found on the circuit board.
- ▶ Cables to the analogue sensors/encoders should be connected as directly as possible (avoid the use of terminals and terminal blocks).

Temperature measurement AI (T)

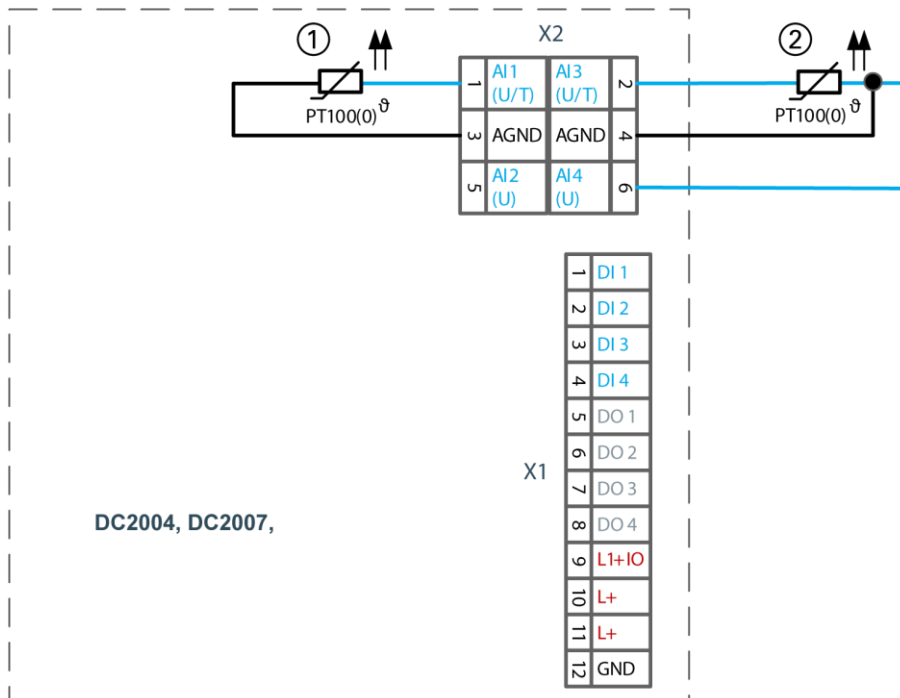

Fig. 37: Connection example: temperature measurement

No.	Description
1	PT 100 with 2-wire connection
2	PT 100 with 3-wire connection

- ▶ Only use the corresponding AGND for each input.
- ▶ Do not connect AGNDs from different channels.
- ▶ Do not connect to the common GND. The required connections can already be found on the circuit board.
- ▶ Cables to the PT100(0) sensors should be connected as directly as possible and without detours (avoid the use of terminals and terminal blocks).
- ▶ Only connect PT100(0) sensors to AI (U/T) channels.

2-wire measurement

Resistance can result in a measurement error, which in the case of long cables with a small cross-section can be up to 10°. If the temperature of the sensor is known, this deviation can be subtracted and compensated through the software (alternatively, use 3-wire measurement).

3-wire measurement

The nearest AI (U) connection is used to compensate the resistance in the cable. It can only be used directly in conjunction with the following AI (U/T) channel. Channels 1 and 2, and also channels 3 and 4 each form a pair for 3-wire measurement.

5.2.5 Ethernet

The onboard Ethernet adapter has one 10/100 Base-T interface with RJ-45 connection for networking. The Ethernet interface X4 (eth0) can be used as a standard Ethernet interface.

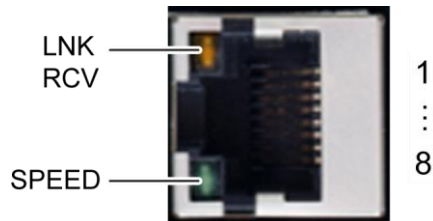

Fig. 38: Ethernet interface X4

Assignment of the Ethernet interface plug X4			
Pin	Assignment	Pin	Assignment
1	TX+	5	NC
2	TX-	6	RX-
3	RX+	7	NC
4	NC	8	NC

LEDs		
LED	Colour	Meaning according to IEEE 802.3 clause 25
LNK/RCV	Yellow	Link, Data Receive Flashing: connection active; data transfer in progress Off: no connection established
SPEED	Green	On = 100 Mbit/s Off = 10 Mbit/s

5.2.6 EtherCAT

The onboard Ethernet adapter has two RJ-45 10/100 Base-T connections for networking. The Ethernet interface X5/6 (eth1) is configured as an EtherCAT master by default but also can be used as standard Ethernet interface.

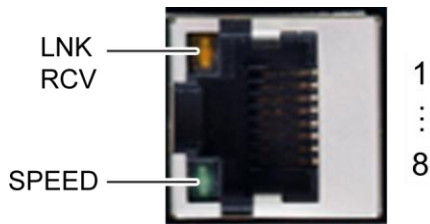

Fig. 39: EtherCAT interface X5

Assignment of the EtherCAT interface plug X5			
Pin	Assignment	Pin	Assignment
1	TX+	5	NC
2	TX-	6	RX-
3	RX+	7	NC
4	NC	8	NC

LEDs		
LED	Colour	Meaning according to IEEE 802.3 clause 25
LNK/RCV	Yellow	Link, Data Receive Flashing: connection active; data transfer in progress Off: no connection established
SPEED	Green	On = 100 Mbit/s Off = 10 Mbit/s

5.2.7 USB

Devices with a USB interface can be connected to the USB host port (Rev. 2.0). Suitable USB device classes are:

CODESYS user: USB thumb drive only

Linux level: USB thumb drive or mouse

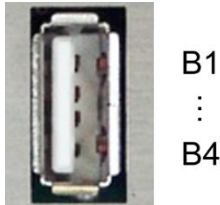

Fig. 40: USB interface X3

Assignment of the USB interface plug X3			
Pin	Assignment	Pin	Assignment
B1	VCC	B3	D+
B2	D-	B4	GND

NOTICE

Damage to the USB thumb drive and malfunctions due to data loss!

Removing a USB thumb drive while it is still in use and data is being transferred can render the USB thumb drive unusable. Open files which cannot be accessed due to removal of the USB thumb drive can block the device.

- ▶ Therefore ensure that all data operations are complete before removing the USB thumb drive.

NOTICE

Property damage and malfunctions due to data loss!

The USB interface is protected against overload ($> 0.5\text{ A}$). In the event of a short-circuit during operation, the controller can trigger a system reset.

This can result in considerable damage to property and damage to the USB device.

- ▶ Before using a USB device, check its power consumption.

NOTICE

Failures and malfunctions when connected directly to signal ground!

- ▶ Only use USB devices that do not have a direct connection between the signal ground and the housing.

USB thumb drives can be inserted and removed during operation. The inserted USB thumb drive is detected automatically and appears in the Linux directory/media/usbX. When the USB thumb drive is removed, the directory /media/usbX is again removed from the directory structure.

Either the first partition on the USB thumb drive, or, if the memory is not partitioned, the entire memory will be connected, i.e. the respective directory appears automatically.

The X represents a number from 1 (first USB device) to 8 (last/max. USB device).



The mechanical design of the USB interface is designed to withstand 1,000 plugging and unplugging cycles.

5.2.8 CAN bus (not all modules)

Properties of the CAN interface	
Standard	ISO 11898
Maximum Baud rate	1 MBit/s
Lowest adjustable Baud rate	50 kBit/s
Contacts	Electrically isolated
Assignment	to CiA303

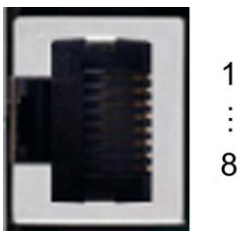

Fig. 41: CAN interface X7 (X12)

Assignment of the CAN interface plug X7 (can0) and optionally X12 (can1)			
Pin	Assignment	Pin	Assignment
1	CAN_H	5	NC
2	CAN_L	6	NC
3	ISO GND	7	ISO GND
4	NC	8	NC

If the interface is located at the start or end of the CAN bus topology:

- Set switch S2 to ON in order to switch on the 120 Ω terminating resistor between CAN_L and CAN_H.

For Baud rates, settings and cable lengths, comply with the recommendations of CiA-303-1.
 Example: at 1 Mbit, max. 25 m

5.2.9 Serial interfaces (from S04 onwards only)

The module has the two serial communications interfaces 1x RS-232 (COM1) and 1x RS-485 (COM2), which are connected via the common RJ45 plug X6.
 Maximum baud rate for both interfaces: 115 kBd

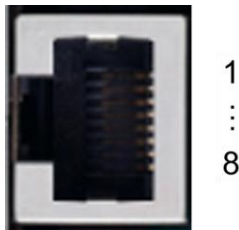

Fig. 42: RS-232/RS-485 interface X6

Assignment for RS-232/RS-485 interface plug X9			
Pin	Assignment/software interface	Pin	Assignment/software interface
1	RS-232 RX/COM 1	5	RS-485 Tx/Rx-/COM 2
2	RS-232 TX/COM 1	6	NC
3	NC	7	(reserved)
4	RS-485 Tx/Rx+ /COM 2	8	ISO GND

The RS-485 interface is “soft” terminated in the dialogue controller with 560 Ω.
 If the interface is located at the start or end of the bus topology:

- ▶ Set switch S3 to ON in order to switch on the 120 Ω terminating resistor.

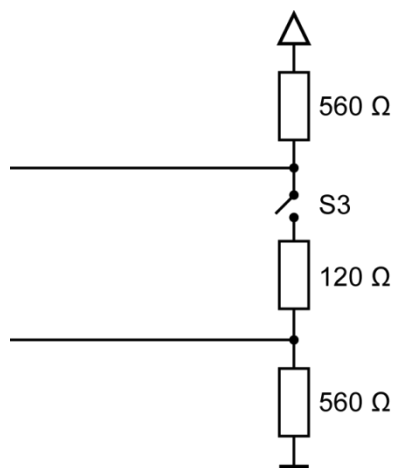

Fig. 43: RS-485 switchable terminating resistor



As far as possible, the assignment of the interfaces should be carried out in accordance with the specifications given in “MODBUS over Serial Line; Specification and Implementation Guide V1.02”.

Signal interference and terminating resistor

To minimise interference, the following instructions must be complied with.

Actively driven bus

- An appropriate protocol must be employed to ensure that at all times one of the bus participants is actively driving the bus.
- For a highly symmetrical signal-noise ratio, the bus must have defined statuses for logical “1” ($A-B < -0.2\text{ V}$) and logical “0” ($A-B > +0.2\text{ V}$).

Undriven bus

- The bus termination must be as asymmetrical as possible to ensure the greatest possible signal-noise ratio (to reduce the symmetrical signal-noise ratio).
- In order to achieve the necessary voltage difference between the signals, a suitable resistor network must be used as the line termination.
- The necessary size of the resistors is governed by the bus length and transmission rate (similarly to the line termination for Profibus, see DIN EN 61158-2).

Connections with GND

To minimise common-mode interference or malfunctions due to potential differences:

- ▶ Check the topology and line lengths to determine whether additional connections to GND are necessary.
- ▶ For electrically isolated interfaces with connections to the reference ground at one point: link to GND.
- ▶ Where necessary, provide an attenuated link to GND (e.g. via $200\ \Omega$) at multiple points.

6 Operation

6.1 Switching on and off

NOTICE

Damage or malfunction!

- ▶ Do not insert, connect, undo or touch any connections while the device is in operation.
 - ▶ Before starting any work on the device, switch off all power supplies, including those to any connected peripherals (externally powered encoders, programming devices etc.).
-

NOTICE

Damage to property!

- ▶ Before connecting the power supply, ensure that all cabling and the polarity of all the connections are correct.
-

Switching on

The device does not have an on/off switch. The device starts automatically when the system is switched on or the power is connected.

Switching off

The device is switched off when the system is switched off or the power supply is disconnected.

6.2 Initial start-up of the network

6.2.1 Web interface configuration

The device must be connected to the network with the correct settings before it can be used.

NOTICE

Damage to property!

- ▶ Before connecting the power supply, ensure that all cabling and the polarity of all the connections are correct.

1st Supply power to the device (24 V).

After start up, the current IP-address and net mask of the device are shown in the top right of the display.

2nd Connect the device to a programming computer using a network cable (X4) and network switch.

3rd Open a web browser on the programming computer.

4th Enter the IP address of the device into the web browser.

The login window is displayed.

User Login:

Name:

Password:

Fig. 44: Login window

5th Name: admin

The default password, which is printed on the device label, serves as the password.

NOTICE

Devices without a password on the device label

If your device does not have a password printed on the device label, the username and password are the same.

e.g. User: admin / Password: admin.

The web configuration page will be displayed.

Configuration

[Network](#)
[Real-Time-Clock](#)
[Display](#)
[FTP-Server](#)
[Users](#)

System

[Info](#)
[Update](#)
[Reboot](#)
[Format Filesys](#)

PLC-Manager

[Control](#)
[Application Info](#)
[Application Files](#)
[Font Files](#)

Fig. 45: List of web interface settings

- 6th Click on the “Network” link.
The “Network Configuration” page will be displayed.

Network Configuration

COMMON

Hostname	<input type="text" value="BGH-IMX6"/>
Default Gateway	<input type="text" value="0.0.0.0"/>
DNS Server 1	<input type="text" value="0.0.0.0"/>
DNS Server 2	<input type="text" value="0.0.0.0"/>

ETH0

Mode:	<input type="text" value="static"/>
IPAdress	<input type="text" value="169.254.255.100"/>
NetMask	<input type="text" value="255.255.255.0"/>

ETH1

Mode:	<input type="text" value="ethernet"/>
-------	---------------------------------------

Fig. 46: “Network Configuration” page

- 7th Check the network settings and make any changes in the text boxes, if required.
Compact HMI Pro 4/7 configuration: ETH0 = X4, ETH1 = X5
Compact HMI Pro 10/15 configuration: ETH0 = X4, ETH1 = X6
- 8th Save the settings by clicking on “Save”.
- 9th Additional settings can also be viewed and/or modified on the web configuration page (e.g. “System time”, display resolution, TargetVisu).

10th In order to accept all of the modified settings, reboot the device:

Briefly disconnect the device from the power supply.

– or –

Click on “Reboot” in the web interface and then confirm on the next page by clicking on “Reboot Module”.

The device is configured and ready for use.

6.2.2 On-screen configuration

NOTICE

Damage to property!

- ▶ Before connecting the power supply, ensure that all cabling and the polarity of all the connections are correct.

1st Supply power to the device (24 V).

After startup, the current IP-address and net mask of the device are shown in the top right of the display.



Fig. 47: Device's main screen

2nd TO change the IP address on the display, press the “Settings” (1) symbol.

The device's Network Settings page appears.

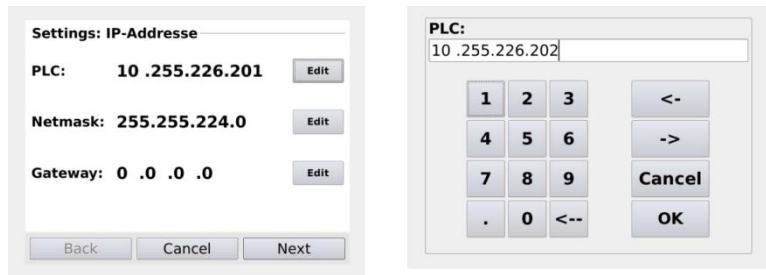

Fig. 48: Network settings

3rd If necessary, press the "Edit" button and change the network setting accordingly (IP address, net mask, gateway).

4th Press the "Next" button.

The page with the network settings summary appears.

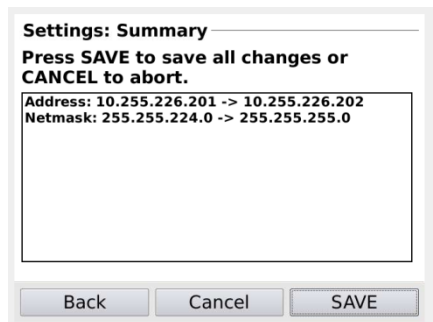

Fig. 49: Network settings summary

5th To change other settings or to correct changes, press the "Back" button.

6th If no settings have been changed, press the "OK" button.

The device's main page appears.

– or –

Press the "Save" button.

The settings are saved and the device reboots automatically.

The device is configured and ready for use.

6.3 Operation

6.3.1 Status indicators

The status indicator function is dependent on the software development environment used in conjunction with the device.

The operating status LEDs show the current status of the power supply, the module mode and any error messages.

The signals from the LEDs depend on the current operating status of the device:

CODESYS inactive: the firmware controls the LEDs.

CODESYS active: only the CODESYS runtime system (CODESYS Runtime) controls the LEDs.

Location of the operating status LEDs

The Run/Stop and Error LEDs display the system status.

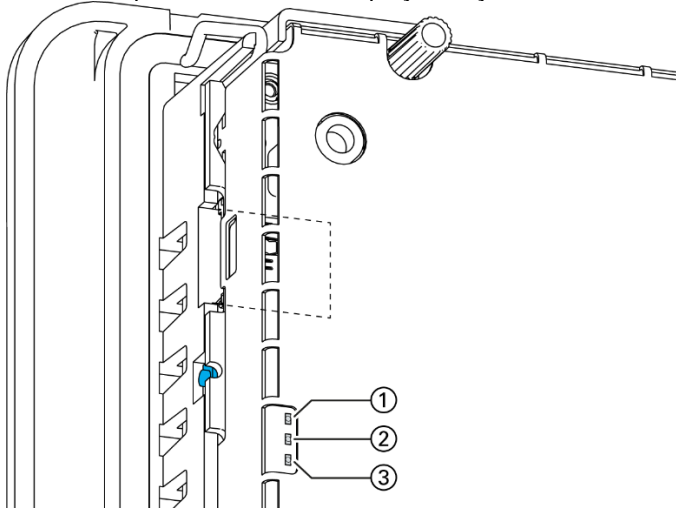

Fig. 50: Location of the operating status LEDs

LED	Meaning
1 PWR (green)	Shows that the power supply to the module electronics is correct.
2 Run/Stop (yellow/green/red)	Shows the system statuses.
3 Error (red)	Shows that the device has been stopped due to an error.

Meaning of the LED displays

System statuses are shown using flashing signals on the Run/Stop LED in yellow.

CODESYS operating statuses are shown via continuous illumination of the Run/Stop LED as either red or green.

While the Run/Stop light is flashing yellow: the device is in use and must not be switched off.

During the boot process, the device does not give any warnings via the LEDs.

6.3.2 Function key (S1)

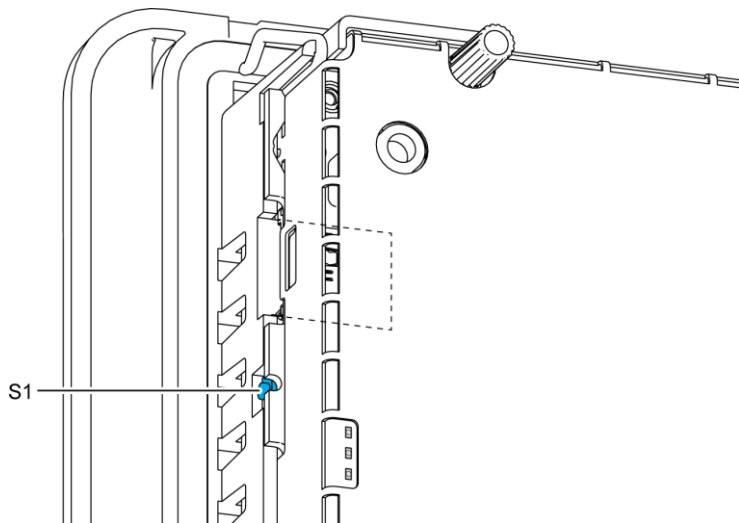

Fig. 51: Function key (S1)

Function key (S1)		
Operating status	Action	Command
Boot phase	Press.	Change to maintenance mode
CODESYS PLC/ CP1131-P	Press briefly.	Change between PLC run and stop mode
	Press and hold.	Stop PLC with reset of variables (cold reset)

6.3.3 Real time clock with battery back-up

Setting the date and time

The time can be set via the web configuration page or the CODESYS V3 library.

Changing the battery

The battery is not designed to be changed by the user; the manufacturer should be contacted in order to change the battery.



For batteries according to UN 3091-PI 970 Section II Button Cell, further information according to the manufacturer's PSDS/MSDS applies.

6.3.4 microSD Card (not all modules)

WARNING

Serious injury as a result of uncontrolled and unpredictable operational behaviour!

Inserting or removing the microSD card can result in the device malfunctioning. The failure of electronic control systems may result in uncontrolled and unpredictable operational behaviour.

- ▶ Insert or remove a microSD card only when the device is switched off.

NOTICE

Loss of data!

MicroSD cards do not have their own write protection system.

- ▶ Ensure that no data is deleted or overwritten by accident.

Inserting a microSD card

- 1st Switch the device off.
- 2nd Insert the microSD card into the microSD card slot.
- 3rd Switch the device on again.

The microSD card is now ready for data transfer (read, write and copy).

Path: /media/sd



Max. possible storage capacity of a microSD card: 32 GB.

The operating life of the gold-plated contacts is up to 10,000 plugging and unplugging cycles.

The microSD card drive has a push-in/push-out insertion and ejection mechanism.

To avoid malfunction, the microSD card may not be removed by pulling.

6.4 Troubleshooting

6.4.1 No network connection

- ▶ Check the wiring/switch.
- ▶ Check whether an IP address has been assigned twice.
- ▶ Check the network settings on the PC: The subnet and subnet mask must match the settings in the controller.
- ▶ Check firewall/anti-virus programs on the PC.

6.4.2 In error stop mode

- 1st Log into device on web browser
- 2nd Establish cause of fault (Diagnostics > PLC Log/System Log).
- 3rd Correct the cause of the fault.
- 4th Restart the device (press "Reset" on the device).
- 5th Device is ready for use.

7 Servicing / Maintenance

Repairs and corrective maintenance may only be carried out by the manufacturer or its authorised customer service centres.

7.1 Maintenance

WARNING

Uncontrolled and unpredictable operational behaviour!

Failures or malfunctions may result in uncontrolled and unpredictable operational behaviour.

- ▶ Do not insert, connect, undo or touch any connections while the device is in operation.
- ▶ Before starting any work on the device, switch off all power supplies, including those to any connected peripherals (externally powered encoders, programming devices etc.).

If the device is used correctly it should not require maintenance.

- ▶ Make sure all the ventilation openings are kept free of obstructions
- ▶ Do not open the device. If it is necessary to work in the device, contact the Service department.

7.2 Cleaning

NOTICE

Damage to the front panel!

The front panel is made of glass and must not be exposed to any mechanical or chemical stress.

- ▶ Do not use any high-pressure cleaners or steam jets.
- ▶ Do not use any corrosive cleaning products, thinners, abrasive media or hard objects to clean it.
- ▶ Do not apply any undue force to the front face.

-
- ▶ To avoid faults due to inadvertent activation, switch the device off before cleaning the front panel.
 - ▶ Only clean surfaces using a dry, lint-free cloth.

7.3 Chemical resistance

7.3.1 Resistance of the touch screen

The active area of the touch screen is resistant to the following chemicals when exposed to them for a period of up to an hour at a temperature of max. 21 °C:

Domestic and industrial chemicals

Detergent, all-purpose cleaners, washing-up liquid, glass cleaner, hydrogen peroxide (3%), Lysol
Ethanol, isopropanol, acetone, methyl ethyl ketone, toluene, concentrated hydrochloric acid, petroleum
White spirit, petrol, engine oil, diesel, gear oil, brake fluid, anti-freeze
Hydraulic oil

Condiments

Lemon juice, tomato juice, mustard, tomato ketchup

7.3.2 Resistance of the front membrane display

NOTICE

Damage to the front membrane display!

The front membrane display is not resistant to the following chemicals or influences, and can be damaged by their effects:

Benzyl alcohol
Concentrated alkalis
Concentrated inorganic acids
Dichloromethane (methylene chloride)
High-pressure steam above 100°C
Long-term effects of direct sunlight

- ▶ Keep these substances away from the front membrane display.
- ▶ Protect the display against direct sunlight.

The front membrane display (Autoflex EB) is based on a polyester membrane with biaxial alignment. It is highly resistant to solvents.

The front membrane display is resistant to the following chemicals in accordance with standard DIN 42 115 part 2, without any evident change or damage:

Application of more than 24 hours

1,1,1 trichloroethane, aliphatic hydrocarbons, benzene, cyclohexanol
Diethyl ether, ethanol

Acetaldehyde, acetone, acetic acid < 50%, sulphuric acid 30%, diacetone alcohol, 1.4 dioxane
DS2 decontamination fluid, fabric conditioner

Acetonitrile, alkali carbonate, ammonia < 32%, Sal ammoniac < 10%, bichromate, caustic potash (potassium hydroxide) < 2%

Sodium hydroxide 50%, refrigerant (Hysol X), diesel oil, castor oil, silver nitrate 20%, ethyl acetate
Acetaldehyde, fluorochlorinated hydrocarbons, glycerine, isopropanol, methanol

Ferric chloride < 30%, formic acid (methane acid) < 50%, hydrochloric acid < 10%

Hydrogen peroxide < 25%, isophorone, methyl ethyl ketone (butanone), nitric acid < 10%

Tetrahydrofuran, formaldehyde (37%) in water

Linseed oil, paraffin oil, petrol, silicone oil, turpentine substitute, universal brake fluid (e.g. Castrol Gir-
ling), dibasic ester 6, Skydrol 500B4, Lixtop, potassium ferrocyanide

Tetrachloroethylene (perchloro ethylene), toluene, triacetin, trichloroethylene, xylene

Phosphoric acid < 30%, potash, sodium hypochlorite < 20%, sulphuric acid < 10%, detergent

Saturated seawater solution

Application of 24 hours at 50°C

Top Job, Jet Dry, Gumption, Fantastic, Formula 409, grape juice, milk, Ariel, Persil, Wisk, Lenor

Downey, Ajax, Vim, Domestos, Vortex, Windex

Application of less than 1 hour

Glacial acetic acid (pure acetic acid)

8 Disassembly

8.1 Disassembling the Compact HMI Pro 4/7

- 1st Disconnect the device and associated peripherals from the power supply.
- 2nd Unplug all plugs and cables.
- 3rd Device with twist-lock catches: Using a T9x50 screwdriver, fully open the twist-lock catches and turn them anti-clockwise to the stop.

NOTICE

Damage to the device!

If the device is disassembled carelessly, it may fall out of the installation cut-out or get damaged.

- ▶ Do not tilt the device.
- ▶ Secure the device to prevent it from falling, particularly when removing it from the control cabinet.

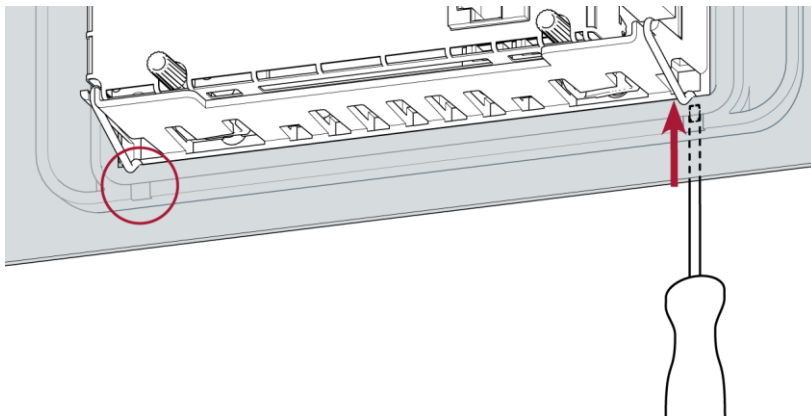

Fig. 52: Loosening the fastening clips (Compact HMI Pro 4/7)

- 4th Using a slotted screwdriver (blade 3–3.5 mm), undo the fastening clips.
Compact HMI Pro 4: 4 fastening clips (2 at the bottom, 2 at the top)
Compact HMI Pro 7: 6 fastening clips (3 at the bottom, 3 at the top)
- 5th Push the device sufficiently far out of the installation cut-out that the fastening clips are no longer engaged.

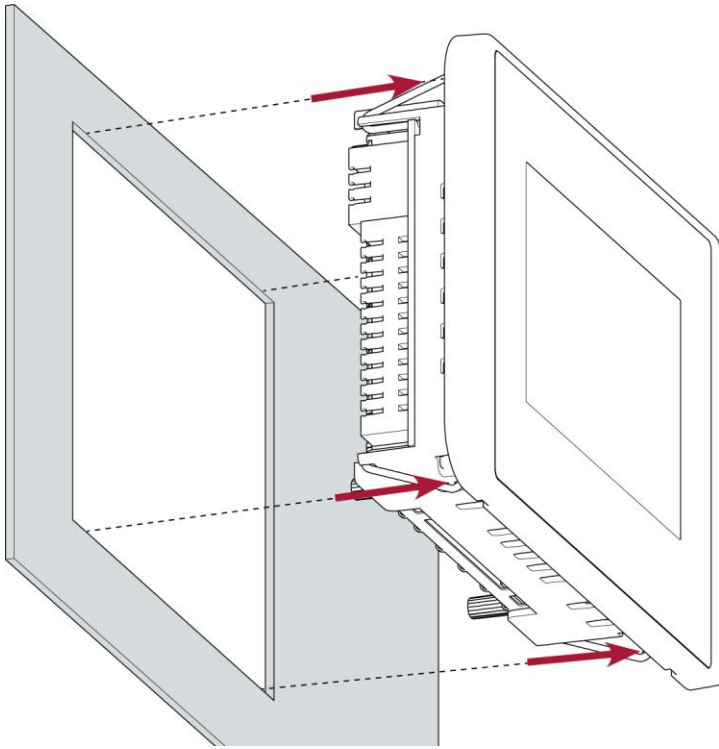

Fig. 53: Pushing the device out of the installation cut-out

6th Push the device evenly forwards out of the installation cut-out.

8.2 Disassembly of the Compact HMI Pro 10/15

- 1st Disconnect the device and associated peripherals from the power supply.
- 2nd Unplug all plugs and cables.

NOTICE

Damage to the device!

If the device is disassembled carelessly, it may fall out of the installation cut-out or get damaged.

- ▶ Do not tilt the device.
- ▶ Secure the device to prevent it from falling, particularly when removing it from the control cabinet.

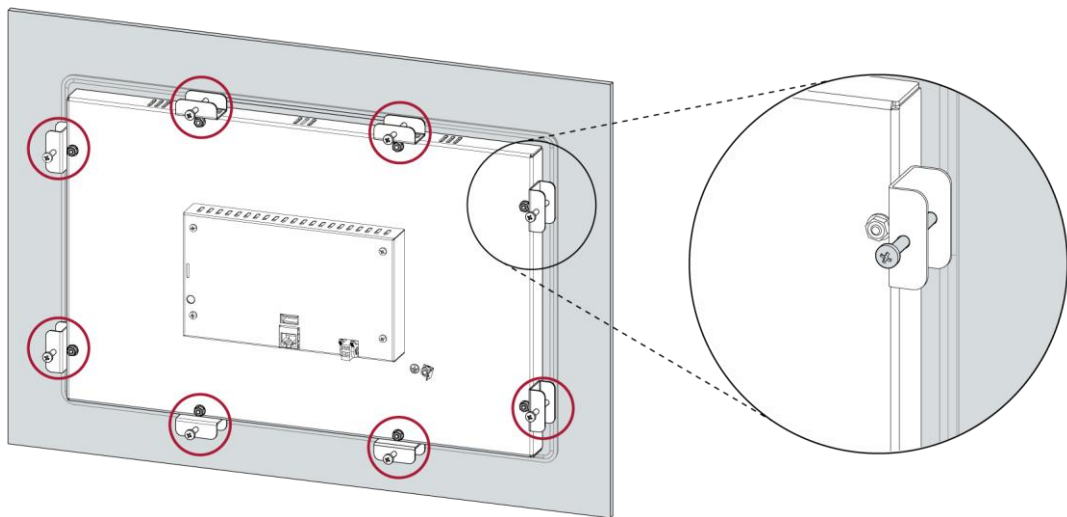

Fig. 55: Loosening the screws

- 3rd Loosen the screws of the 6/8 clamps evenly.

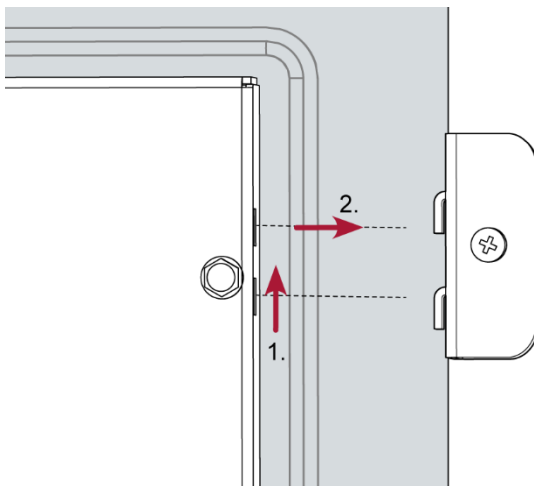

Fig. 56 Removing the tensioning clamps

4th Remove the 8 tensioning clamps.

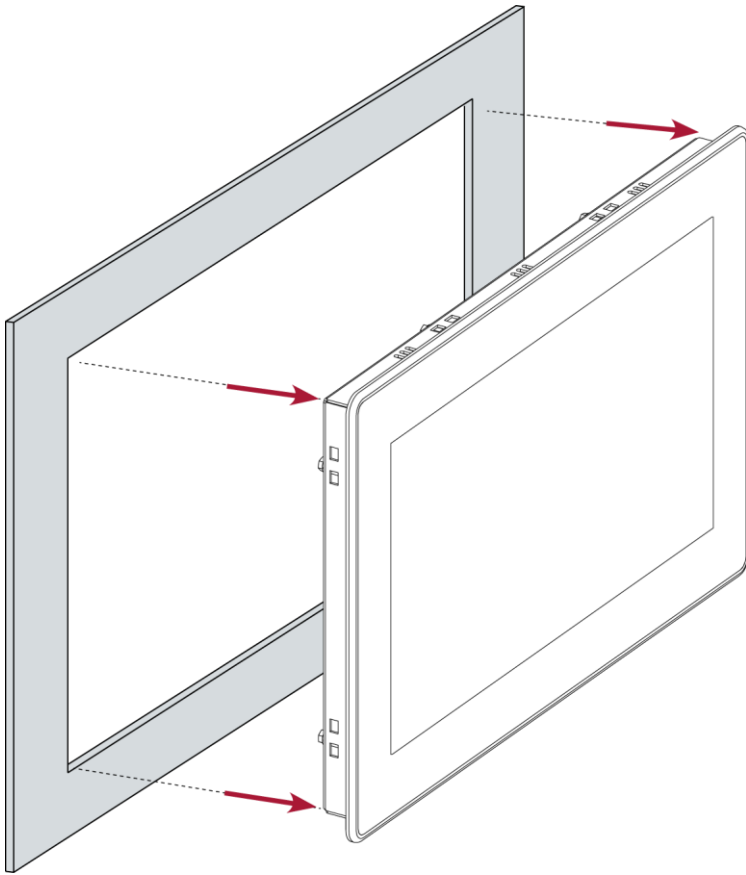

Fig. 57: Pushing the device out of the installation cut-out

5th Push the device evenly forwards out of the installation cut-out.

9 Disposal

The device contains the following components which need to be disposed of separately:

- Metals
- Electronic components
- Battery

The respective national regulations for the disposal of electrical appliances in B2B business apply.

The following options are available for disposal of the device:

Disposal by the manufacturer

Unless otherwise agreed, devices can be returned for disposal.

Disposal in accordance with regional regulations

- ▶ Dismantle the device and disassemble it completely into its component parts.
- ▶ Send the metal parts for metal recycling.
- ▶ Sort the electronic parts (circuit boards, drives, etc.).
- ▶ Dispose of electronic scrap in accordance with the national laws and regulations.
- ▶ Make sure that the battery is completely discharged.
- ▶ Dispose of batteries at a recognised collection point in accordance with national laws and regulations.

10 Information and options

Astraada One Compact HMI Pro Dialog controller	Compact HMI Pro 4	Compact HMI Pro 7		Compact HMI Pro 10	Compact HMI Pro 15
Display	WQVGA	WVGA		WXGA	WXGA
Diagonals	4.3"	7"		10.1"	15.6"
Item no. (Single Core)	S-01010103-0101 S-01010103-0201 S-01010103-0301 (discontinued) S-01010103-0401 S-01010103-0501	S-01010103-0104 S-01010103-0204 S-01010103-0304 (discontinued) S-01010103-0404 S-01010103-0504		S-01010103-0105 S-01010103-0205 S-01010103-0305	S-01010103-0108 S-01010103-0208 S-01010103-0308
(Dual Core)	S-01010103-2401 S-01010103-2501	S-01010103-2404 S-01010103-2504		S-01010103-0405 S-01010103-0505 S-01010103-2405 S-01010103-2505	S-01010103-0408 S-01010103-0508 S-01010103-2408 S-01010103-2508
Resolution	480 x 272 pixels	800 x 480 pixels		1280 x 800 pixels	1366 x 768 pixels
Colours		TFT: 16.7 M (24 bits/pixels)			
CPU		<i>Single Core:</i> 800 MHz ARM® CPU Cortex™- A9 <i>Dual Core:</i> 2x 800 MHz ARM® CPU Cortex™- A9			
Program memory (flash)	256 MB			<i>Single Core:</i> 512 MB to 2 GB (depending on version) <i>Dual Core:</i> 2 GB	
Data memory (RAM)	<i>Single Core:</i> 256 MB <i>Dual Core:</i> 512 MB			<i>Single Core:</i> 512 MB <i>Dual Core:</i> 1 GB	
Retain memory (FRAM)		100 kB			

Dimensions (WxHxD)	161 x 103 x 46 mm	224 x 152 x 46 mm		283 x 198 x 55 mm	425 x 280 x 55 mm
Weight	approx. 450 g	approx. 600 g		2.5 kg	approx. 3 kg
Ambient temperature		<i>Compact HMI Pro 4 ; Compact HMI Pro 7;;Compact HMI Pro 10; Compact HMI Pro 15 ; Compact HMI Pro 10 Duo; Compact HMI Pro 15 Duo:</i> 0°C to 55°C <i>Compact HMI Pro 4 Duo; Compact HMI Pro 7 Duo;:</i> 0°C to 50°C			
Relative humidity		max. 85%, non-condensing			
Ambient temperature	Transport and storage	-20°C to +70°C			
Relative humidity	Transport and storage	.max. 85%, non-condensing			
Assembly	integrated securing clips			Bolt mounting, tensioning clamps for IP65	Removable tensioning clamps
Certification	CE (EN 61131-2) cUL _{us} (UL 61010-2-201)			CE (EN 61131-2)	CE (EN 61131-2)
Development environment		CODESYS V3 (IEC 61131-3)			
Touch operation		Resistive			
Shock resistance					
Vibration		sinusoidal (EN 60068-2-6) test: Fc 10-150 Hz, 10 m/s ²			
Shock		15 G (approx. 150 m/s ²), 11 ms duration, half-sine (EN 60068-2-27) Test: Ea			
EMC, protection rating					
Emission standard	EN 61131-2; EN 61000-6-3, living area			EN 61131-2; EN 61000-6-4, industrial area	
Resistance to interference	EN 61131-2; EN 61000-6-2, industrial area			EN 61131-2; EN 61000-6-2, industrial area	

Protection class	III			
Isolation protection	EN 61131-2; 500 VDC test voltage			
Protection rating	IP20, front IP54 (IP65 only with twist locks catches tightend)		IP20, front IP54 (IP65 only with all tensioning clamps attached)	
Front membrane	Autoflex			
Outdoor use	Autoflex is unsuitable for long-term exposure to direct sunlight.			
Power supply (24 V power supply unit)				
Supply voltage	+24 VDC (-15% / +20%) SELV max. AC voltage component 5%			
Power consumption	Total max. 3A at +24V DC (0,3A PLC internal; 2,7A digital outputs)	Total max. 3A at +24V DC (0,3A PLC internal; 2,7A digital outputs)	Total max. 3,5A at +24V DC (0,8A PLC internal; 2,7A digital outputs)	Total max. 3,6A at +24V DC (0,9A PLC internal; 2,7A digital outputs)
Protection against reverse polarity	Yes			
Bridging in case of power failure	10 ms at < 20.4 V DC			
Ethernet interfaces				
No. / type of interface	1x 10/100 Base T			
Connection system	RJ45			
Protocols	Standard: TCP/IP, NTP, FTP Option: Modbus TCP, BACnet, Profinet, EthernetIP, SNMP, KNX, OPCuA, IoT			
EtherCAT interface				
No. / type of interface	1x EtherCAT (EtherCAT Master), can also be configured as ethernet			
Connection system	RJ45			
USB interfaces				
No. / type of interface	1x host USB 2.0 / USB plug type A		2x host USB 2.0 / USB plug type A	

No. plugging/unplugging cycles	max. 1,000
CAN bus interfaces	
No. / type of interface	up to 2x CAN bus
Connection system	RJ45
Protocols	Standard: CAN Layer 2, CANOpen Master Option: J1939
Serial interfaces	
No. / type of interface	Up to 1x RS-232/1 x RS-485
Connection system	RJ45, combiport
Protocols	Standard: Serial communication Option: Modbus RTU
Additional functions	
Real-time clock	Yes, rechargeable battery buffered
microSD card slot	1x microSD card (up to 32GB SDHC)
I/O	
Digital IN	Up to 4x
Digital OUT	Up to 4x (0.5 A)
Analogue IN	Up to 2x (-10 - +10 V, PT100/PT1000 with 2-wire) Up to 2x (-10 - +10 V, or return for 3-wire)
Rechargeable battery	
Type	Panasonic VL2020 or similar
Lifetime	10 years (depending on operating temperature)
Storage	At least one month without voltage (RTC data may be lost in case of longer storage periods)

10.1 Type plate

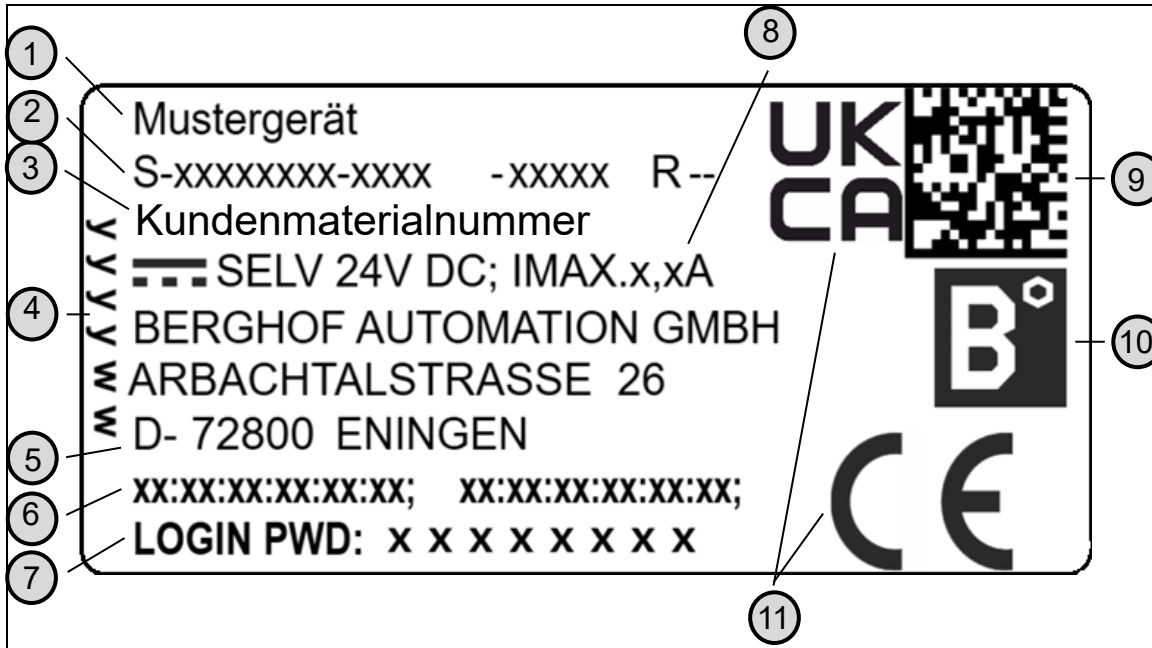

Fig. 58: Type plate (example)

No.	Designation	No.	Designation
1	Product description	7	Default password
2	Order number / serial number / version identification	8	Supply voltage and maximum current
3	Customer material number	9	QR code (identification no.)
4	Production date (year/week)	10	Manufacturer's logo
5	Manufacturer (manufacturer's address)	11	Conformity marking
6	MAC addresses of the unit		

10.2 Device variants and identification

Designation	Order number	Features
Compact HMI Pro 4 S01	S-01010103-0101	4.3" display, RTC, μ SD card slot , 2 x Ethernet
Compact HMI Pro 4 S02	S-01010103-0201	+ 1 xCAN bus,1 x RS232; 1 x RS485
Compact HMI Pro 4 S04	S-01010103-0401	+ 4 x AI, 4 x DI , 4 x DO
Compact HMI Pro 4 S05	S-01010103-0501	+ additional 2. CAN bus
Compact HMI Pro 7 S01	S-01010103-0104	7" display, RTC, μ SD card slot , 2 x Ethernet
Compact HMI Pro 7 S02	S-01010103-0204	+ 1 xCAN bus,1 x RS232; 1 x RS485
Compact HMI Pro 7 S04	S-01010103-0404	+ 4 x AI, 4 x DI , 4 x DO
Compact HMI Pro 7 S05	S-01010103-0504	+ additional 2. CAN bus
Compact HMI Pro 10 S01	S-01010103-0105	10.1" Display, RTC, 2 x Ethernet, 4 x DI, 4 x DO
Compact HMI Pro 10 S02	S-01010103-0205	+ 4 x AI,
Compact HMI Pro 10 S03	S-01010103-0305	+ 1 x CAN bus; μ SD card slot
Compact HMI Pro 10 S04	S-01010103-0405	+ 1 x RS232, 1 x RS 485
Compact HMI Pro 10 S05	S-01010103-0505	+ additional CAN bus,
Compact HMI Pro 15 S01	S-01010103-0108	15.6" Display, RTC, 2 x Ethernet, 4 x DI, 4 x DO
Compact HMI Pro 15 S02	S-01010103-0208	+ 4 x AI,
Compact HMI Pro 15 S03	S-01010103-0308	+ 1 x CAN bus; μ SD card slot
Compact HMI Pro 15 S04	S-01010103-0408	+ 1 x RS232, 1 x RS 485
Compact HMI Pro 15 S05	S-01010103-0508	+ additional 2. CAN bus,

The features individual versions have changed. For questions about older versions, our technical support will be glad to help you.

10.3 Options and extensions

Options are ordered via the combination
"Order number option1 option2..."

e.g.: **S-01010104-0204 S001 S002 H001**

In addition to the order number, additional extensions in the form of hardware, software and customised options are indicated as follows:

Option code	Option type
S000-S999	Software options e.g. field buses
H000-H999	Hardware options e.g. plug kit, certifications
C000-C999	Customised options e.g. customised firmware, customised front membrane display

For more information about the options available for this device, please refer to our product catalogue or website.

The additional features included or installed in each device are listed on the options label. This label can be found on the device and/or on the packaging.



Fig. 59: Options label

11 Certificates

11.1 Standards

Applicable directives

- EMC Directive 2014/30/EU
- RoHS Directive 2011/65/EU

Applicable standards

- Standard
EN 63000:2019-05
- PLC standard
EN 61131-2:2008-4
- Emission standard
EN 61000-6-3:2012-11
- Safety provisions
DIN EN 61010-2-201

12 Appendix

12.1 Notes on copyright and the software licence

The device's firmware contains free software. Parts of this software are available under the following and other open source licences:

- GNU General Public License (GPL)
- GNU Lesser General Public License (LGPL)
- Mozilla Public License (MPL)
- FreeType License (FTL)

12.2 List of figures

Fig. 1: Overview of Compact HMI Pro 4/7 (rear)	15
Fig. 3: Overview of Compact HMI Pro 10/15 (rear)	16
Fig. 4: Compact HMI Pro 4 dimensions.....	21
Fig. 5: DC2004 and ET2004 installation cut-out.....	22
Fig. 6: Compact HMI Pro 7 dimensions.....	23
Fig. 7: Compact HMI Pro 7 and ET Pro 7 installation cut-out.....	24
Fig. 10: Compact HMI Pro 10 dimensions.....	25
Fig. 11: Compact HMI Pro 10 and ET-Pro 10 installation cut-out	26
Fig. 12: Compact HMI Pro 15 dimensions.....	27
Fig. 13: Compact HMI Pro 15 and ET-Pro 15 installation cut-out	28
Fig. 14: Opening the twist-lock catches.....	29
Fig. 15: Installation in an installation cut-out, example with 4 fastening clips	29
Fig. 16: Device clipped into place in the installation cut-out, example with 4 fastening clips.....	30
Fig. 18: Installing in the installation cut-out	31
Fig. 19: Hooking in the tensioning clamps (at the rear)	32
Fig. 20: Tightening the tensioning clamps	32
Fig. 21: Installing in the installation cut-out	33
Fig. 22: Hooking in the tensioning clamps (at the rear)	34
Fig. 23: Tightening the tensioning clamps	34
Fig. 24: Power supply to the Compact HMI Pro 4/7 with power LED (only version S03 – S05)	36
Fig. 25: Power supply to the Compact HMI Pro 4/7 X10 (only for version S01 and S02).....	37
Fig. 26: Power supply to the Compact HMI Pro 10/15 plug X1 with power LED	37
Fig. 27: Block diagram of Compact HMI Pro	39
Fig. 28: Digital input and outputs, Compact HMI Pro plug of rows 1 X1 with LEDs 1 to 8.....	40
Fig. 29: Digital input-and outputs, Compact HMI Pro plug of rows 2 X1 with LEDs 1 to 8.....	41
Fig. 30: Circuit diagram of the principles of positive switching, output	43
Fig. 31: Circuit diagram of the principles of positive switching, input.....	44
Fig. 32: Operating ranges of digital inputs (type 1/3).....	44
Fig. 33: Counter up/down or pulse/direction.....	45
Fig. 34: Counter with capture input	46
Fig. 35: Analogue inputs X2	47
Fig. 36: Connection example: voltage input	52
Fig. 37: Connection example: temperature measurement	53
Fig. 38: Ethernet interface X4	54

Fig. 39: EtherCAT interface X5.....	55
Fig. 40: USB interface X3.....	56
Fig. 41: CAN interface X7 (X12).....	57
Fig. 42: RS-232/RS-485 interface X6.....	58
Fig. 43: RS-485 switchable terminating resistor.....	58
Fig. 44: Login window	61
Fig. 45: List of web interface settings.....	62
Fig. 46: "Network Configuration" page	62
Fig. 47: Device's main screen	63
Fig. 48: Network settings.....	64
Fig. 49: Network settings summary.....	64
Fig. 50: Location of the operating status LEDs.....	65
Fig. 51: Function key (S1)	66
Fig. 52: Loosening the fastening clips (Compact HMI Pro 4/7)	72
Fig. 53: Pushing the device out of the installation cut-out	73
Fig. 55: Loosening the screws.....	74
Fig. 56 Removing the tensioning clamps	74
Fig. 57: Pushing the device out of the installation cut-out	75
Fig. 58: Type plate (example).....	81
Fig. 59: Options label	83